

SL-22025

AUTOMATIC SLIDING GATE OPENER
USER MANUAL

ALTECH AUTOGATE INT. PHILIPPINES INC.
B6 L28 Aphrodite St., Villa Olympia 6
San Pedro, Laguna 4023

@Altech Autogate | @Altech Enterprise



📞 +63 917 870 9928
+63 917 182 0156

☎️ (02) 8398-5669

✉️ autogate.ph@gmail.com

🌐 www.altech.ph

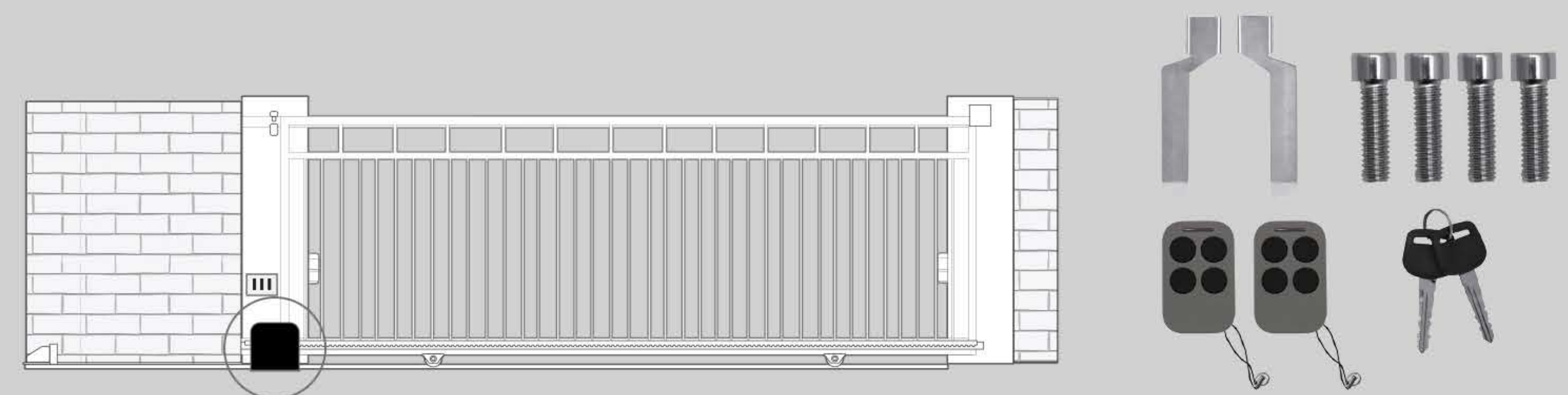

CHECK YOUR GATE

Before installation, please make sure that the gate itself can be opened and closed smoothly & freely BY HAND WITHOUT THE GATE OPENER.

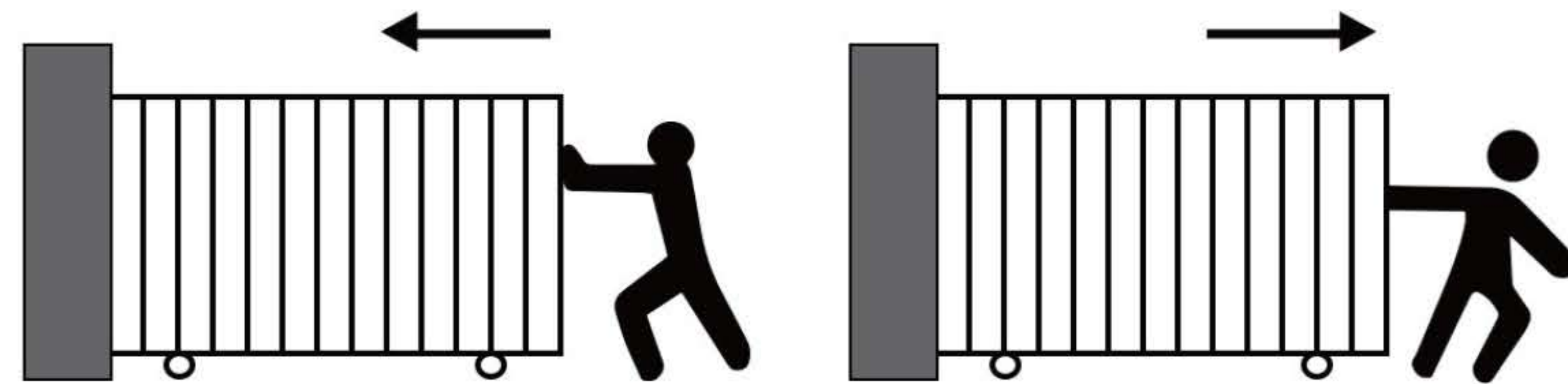

1. General Safety



WARNING! An incorrect installation or improper use of the product can cause damage to persons, animals or properties, should always request the assistance of qualified personnel.

- This product was exclusively designed and manufactured for the use specified in the present documentation. Any other use not specified in this documentation could damage the product and be dangerous.
- The factory declines all responsibility for any consequences resulting from improper use of the product, or use which is different from that expected and specified in the present documentation.
- Do not install the product in explosive atmosphere or where there is any danger of flooding.
- To AVOID damaging gas, power, or other underground utility lines, contact underground utility locating companies BEFORE digging.
- Disconnect the electrical power supply before carrying out any work on the installation or maintenance.
- Please ensure that the using power voltage matches with the supply voltage of gate opener (AC220V±10% 50Hz).
- To ensure safety, before installing the motor, all potential hazards and exposed pinch points of the gate must be eliminated or guarded prior, and make sure Gate End Stop and a Gate Stopper mounted at each end of the rail to prevent the gate travelling off the track.
- Never mount any device that operates the gate motor where the user can reach over, under, around or through the gate to operate the controls. These must be placed at least 1.8m from any moving part of the moving gate.
- Keep remote control and other control devices out of children's reach, in order to avoid unintentional activation.
- If required, install infrared photocells (sold separately) to detect obstructions and prevent injury or damage.
- Instruct all users about the control systems provided and the manual opening operation in case of emergency.
- Anything which is not expressly provided for in these instructions is not allowed and will void warranty.
- Only use original parts for any maintenance or repair operation. We decline all responsibility with respect to the automation safety and correct operation when other supplier's components are used.

10.2 How to Add and Operate the Bluetooth Device:

• Add the bluetooth device:

Open the XHouse IOT app, enter the add device mode, and choose the bluetooth device. Choose the correct bluetooth device, press the add button. (The bluetooth device mode number is XHOUSE_092BLE_XXXXXX, XXXXXX is serial number)

• **Bluetooth device control mode:** The app have open, close, stop control buttons.

• **Reset the bluetooth device:** Hold press the DEC/Smart button about 5s, while you hear the buzzer sound two beep, release the button, the operation is complete.

• **Reset the bluetooth device:** Hold press the DEC/Smart button about 10s, while you hear the buzzer sound with a long beep, release the button. After that, the module will erase all the 2.4G transmitter and reset the bluetooth device.

11.Maintenance

Warning: Please disconnect the power before repairing.

1. When someone or obstructions between the gate, do not open or close the door to ensure safety.
2. The power supply for the control board should be equipped with a separate switch with a fuse rated at 10AMP.
3. There is strong electricity in the control box. Please cut off the power supply before opening the cover.
4. Motor gear modulus $M = 4$, number of teeth = 16, use the corresponding racks.
5. The gate should be as straight as possible, making sure after racks fixed good and the gate can be in a good position with motor gear.
6. Racks and gear should be controlled in good gap. so can make sliding steady.
7. After confirm the direction of gate movement . please check if the limit block fixed in good position to avoid the motor run out of control due to failure..

12.Trouble Shooting

Problem	Possible causes	Repair method
Gate fails to operate	<ol style="list-style-type: none"> 1. Check the clutch states ,power-driven state or not ? 2. Power no indication, and power trip 3. The fuse has broken. 4. Remote control failure or invalid. 5. Damaged power cable. 6. Remote control or motor problem. 	Recovery To restore power Change the fuse Detection or change Detection and Repair Detection and Repair
Working distance of remote control reduced	<ol style="list-style-type: none"> 1. Low battery power or damaged. 2. Interference from equipment using the same frequency. 3. The receiver of controller was damaged. 	Replace battery. Wait eliminate interference. Replace the control board.
Gate fails to stop at start or end position	<ol style="list-style-type: none"> 1.The terminal stop toggle switch is damaged or obstructed. 2. Limit switch of the motor and the limit detection of the interface PCB board plug off. 3. Limit of open and close is in wrong position. 	Replace toggle switch or remove obstruction Insert and fixed it. Adjust of limit switch(K1)
Press open and close key of motor, but can't working and operate	<ol style="list-style-type: none"> 1. Blocked sensitivity is too high(set too big). 2. The gate has lifted off the track and disengaged the drive gear from the rack. 	Make blocked sensitivity lowered ,and check gear and racks can operate normally. Maintenance and replace.

- **Program the remote:** Press learn button for at least 1 second and then release, the LED indicator will light on. Now user needs to press the button on the remote control, with the buzzer short beep, which means the code learning is successful, the digital LED will show the quantity of that remotes were learned.

After the user presses the learn button, within 8 seconds, if the controller doesn't receive the signal from the remote, the controller's LED indicator will turn out and exit the code learning statute.

- **Erase the remote:** Press and hold the learning button for 5 seconds, while the user hears the buzzer with a long beep, release the button, and the digital display show "00". Now all remotes can not control the gate.

- **Max capacity:** 120pcs remote. If the digital display show "- -" with a buzzer short beep 5 times, then means can not learn more remotes.

Note: Due to the digital display only can show two words, if the controller already learned more than 99pcs remote, from the 100th remote, the digital display will show A to replace the ten and hundred digits. Such as the 100th remote will show A0, and the 101st remote will show A1. If the controller already learned more than 109pcs remote, from the 110th remote, the digital display will show b to replace the ten and hundred digits. Such as the 110th remote will show b0.

9. How to Use the Remote to Operate Your Gate Opener

Each remote has 4 buttons, there are two remote control modes for optional. The factory setting is a three-button control mode. If you want to change to use single button control model, please reference the data set of P8 on the digital display.

- **Three-button control mode:** remote 1st button to control gate open, 2nd button to control gate close, 3rd button to control gate stop. 4th button to control gate PED mode.

- **Single button control mode:** the remote button 1 st is used to control the gate as "open-stop-close-stop", the 4th button is used to control the PED mode. Button 2 and 3 are invalid.

Note: If you adjust the remote control mode, please program the remote into your gate opener again to operate it.

10. Smart control mode by adding a smart module (Optional)

If you add the smart module into your control board, you also can use smartphone bluetooth function to control your gate opener by phone on the X-House IOT app. And you also can achieve keyless entry while you driving a car, as long as you plug a 2.4G transmitter into your car.

10.1 How to Program and Operate the 2.4G Transmitter:

- **Program the 2.4G transmitter:** Short press the DEC/Smart button, the buzzer will sound once, smart indicator LED will light on, enter the programming mode.

Power on the 2.4G transmitter, it will auto transmit the 2.4G signal, if the **Smart indicator LED** flash twice and keep lighting on, which means the programming is successful. Otherwise, after 8s will exit the programming mode automatically.

- **Operate to open the gate:** Plug the 2.4G transmitter into the car, while user drive the car and arrive at the front of the gate, the smart module will receive the 2.4G signal and open the gate automatically.

2. Product Description

The PYM-H2207 motor was designed as a device for moving sliding gates. The way of the gear works prevents the gate from moving when the motor is turned off, so there is no need to use an electric lock. Avoid a power failure, user can use the override key to unlock the clutch to manual open or close the gate.

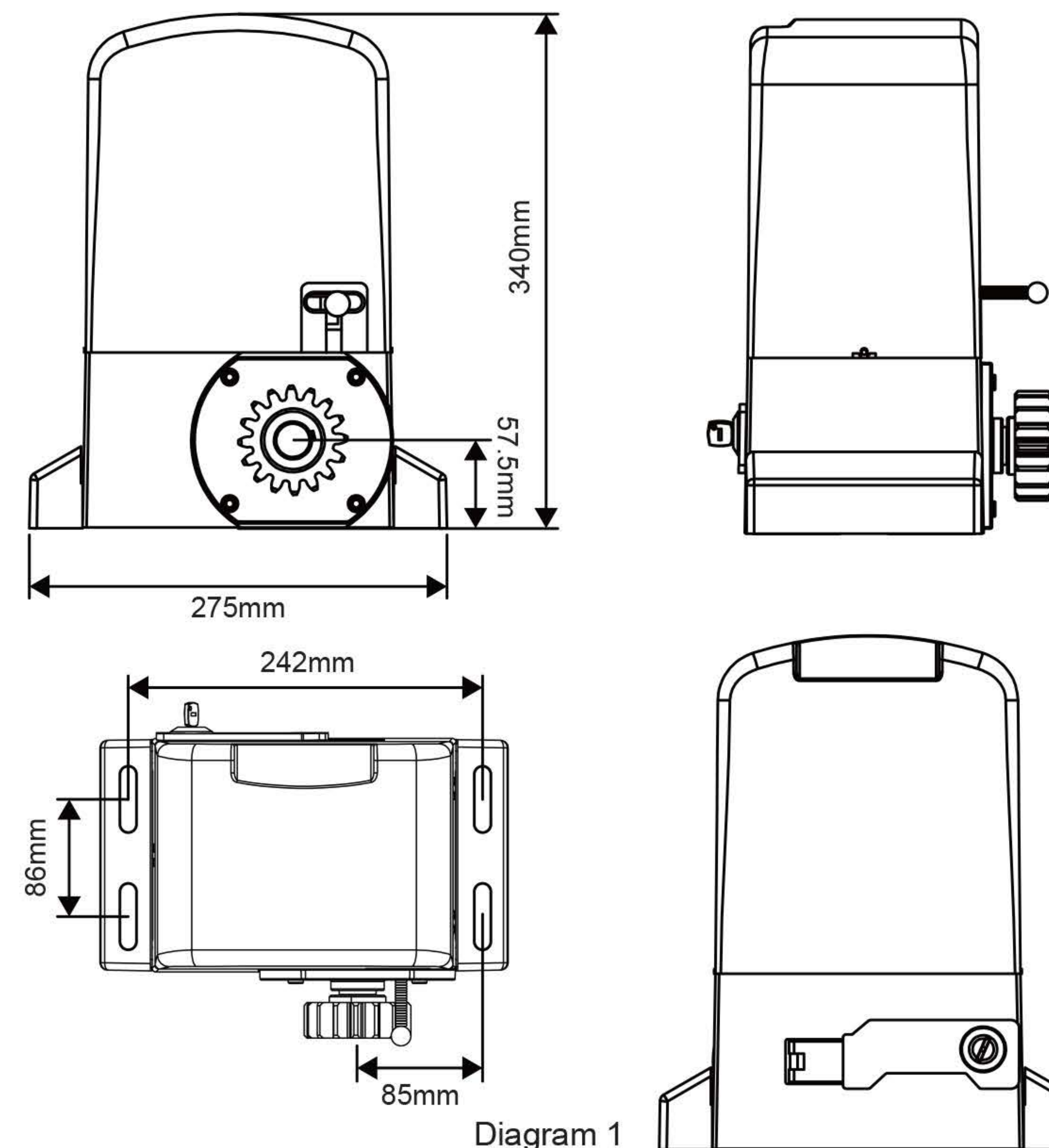
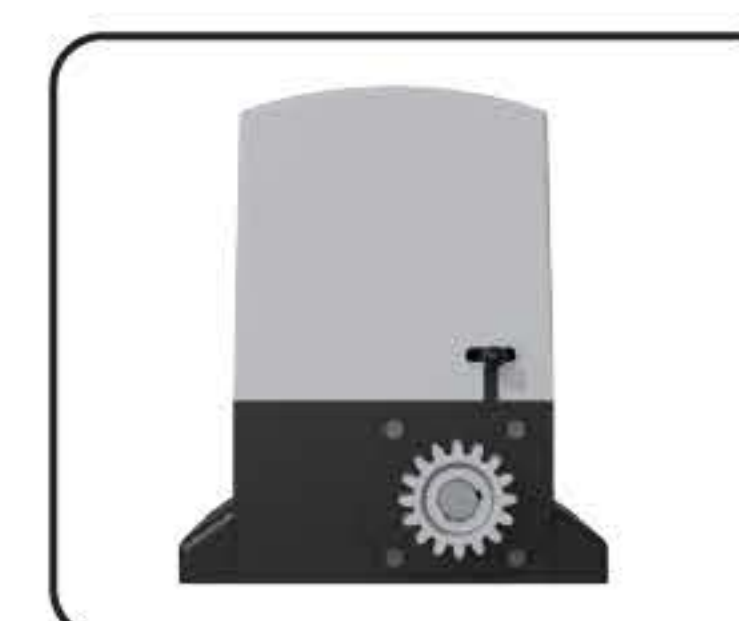

Diagram 1

2.1 Part list



Motorx1



RHS/LHS Limit Switch Striker Platex2



Motor to mounting plate screwsx4



Motor Base Platex1



Adjust Boltsx4



Striker Plate Fixing Boltsx4

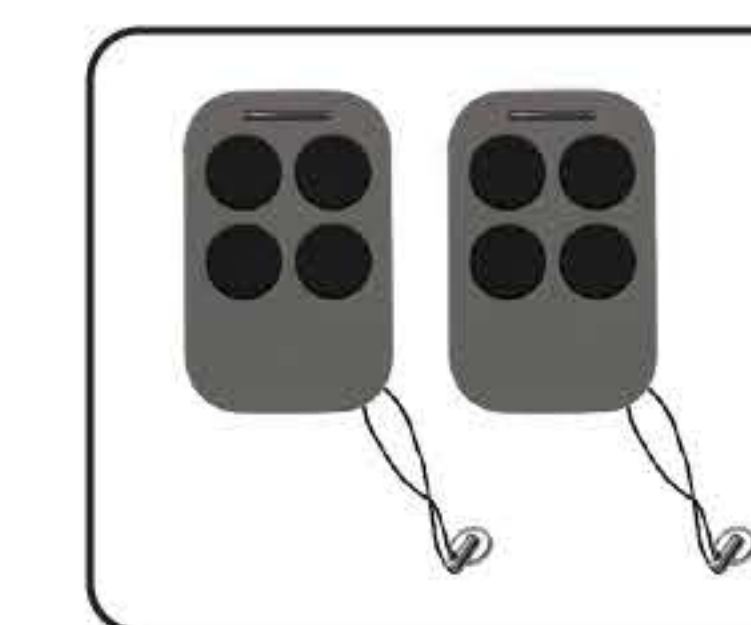

Remotex2



Override keysx2

2.2 Optional Accessories Parts List (Available at Giant Store)

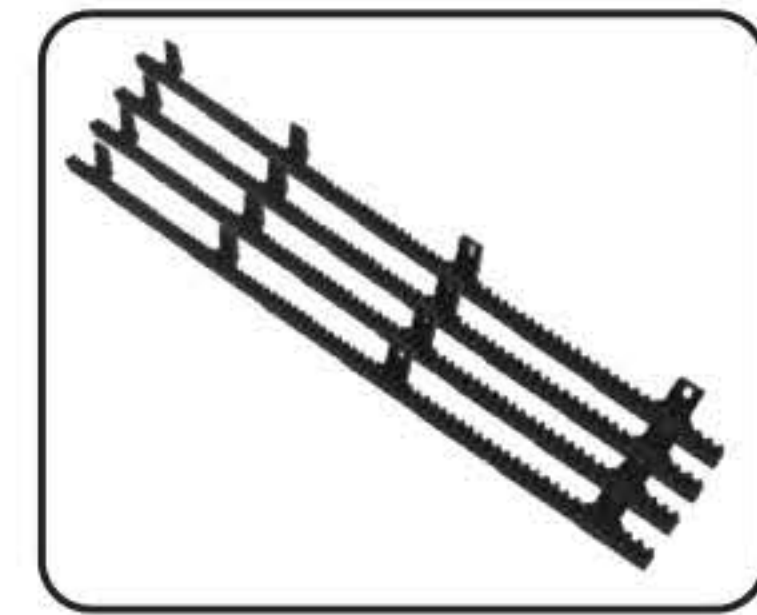

Gear Rack



Photocell Sensor



Flash Lamp



TKM-01



Wifi controller

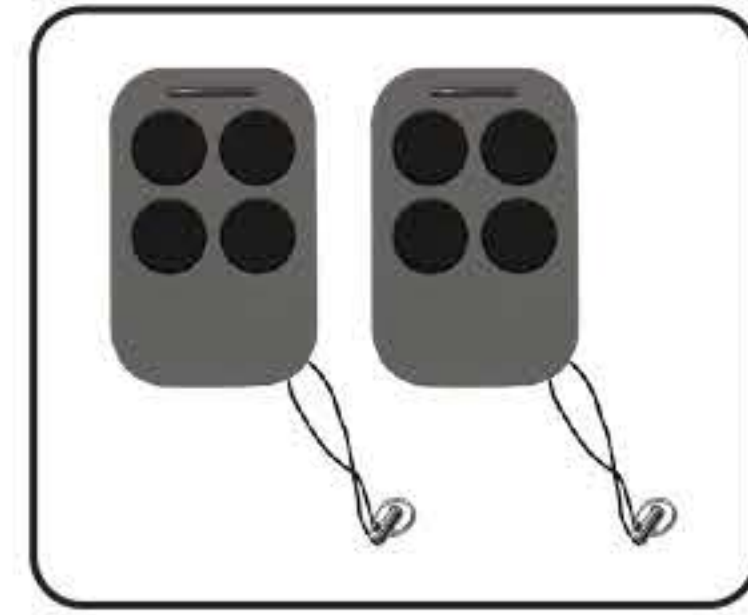

Remote Control



ST-01/02/03



Smartphone Remote Control with Camera

2.3 Technical Specifications

Power supply	Three-phase motor AC 220V±10%
Maximum load	2500KGS
Rated power	250W
Rated speed	1400RPM
Output Speed	50Rr/min±10%
Running speed	12m/min
Output torque	62 N.m
Output gear module	M=4
Output gear number	Z=16
Remote control distance	≤50 meter
Working humidity	≤85%
Maximum pull	2300N
Noise	≤55dB
Protection Class	B
Working temperature of motor	-20°C~ +55°C
Net weight	12KG
Packing	In a standard carton

Features of sliding gate opener

- Soft start and slow stop.
- Automatic closing function adjustable from 1 to 99 seconds.
- Thermal protection against engine overheating.
- Anti-pinch protection in case of meeting an obstacle.
- Signaling the current operating status of the machine on the display.
- Ability to support up to 120pcs remote controls.
- Possibility to assign one of 8 functions to 4 buttons on the remote control.
- Possibility to connect external buttons and control devices (e.g.push button, wifi controller, radio receiver etc).
- Possibility of partial opening of the gate, without the need to perform the full scope of work.
- Manual release of the gate in the event of a lack of 220V mains voltage.
- Add smart module for 2.4G bluetooth control (optional).

Item	Function description	Value	Factory set	Explanation
P0	Low speed resistance sensitivity	0-20 level	12 level	The larger the value, the higher the resistance and the harder it is to meet resistance.
P1	High speed resistance sensitivity	0-20 level	10 level	
P2	Low speed adjustment	0-12 level	5 levels	The larger the value, the faster the slow speed.
P3	High speed adjustment	0-12 level	0	The larger the value, the faster the high speed.
P4	High speed running time	0-60s	12s	0:Turn off high speed
P5	Auto-open gate tiem for PED mode	0-20s	6s	0:PED mode auto-open gate function off
P6	Auto-close gate tiem for PED mode	0-99s	10s	0:PED mode auto-close gate function off
P7	Auto-close gate time	0-99s	0	0: Auto-close function off
P8	Limit switch mode optional	0-1	0	0: NC mode 1: NO mode
P9	RF remote button control mode	0-1	0	0: Three-buttons mode 1: Single button mode
PA	Reduce Speed For High-Speed Mode	0-5 level	0	The larger the value, the stronger the high-speed braking force (the shorter the sliding18 distance when stopping)
Po	Reset to factory setting	0-10	0	5: Reset to factory setting

NOTE:

When gate motor is working, if trigger pedestrian mode then gate motor will stop at once. After 6s of trigger pedestrian mode to open gate The auto open time can set from 0-20s, factory setting is 6s. neither now enter the auto close time count down or stop, if you trigger pedestiran mode again, then gate will auto close at once.

Control board digital display information show:

1. When the gate is start to open, the digital display will show 1S "OP"
2. When the gate is start to close, the digital display will show 1S "CL"
3. After the gate stop moving, the digital display will show 1S "--"
4. When the gate moves to the full open limit, the digital display will show 1S "LO"
5. When the gate moves to the full close limit, the digital display will show 1S "LC"
6. When the motor reaches max working time, the digital display will show 1S "EC"
7. After the motor trigger the overload protection, the digital display will show 1S "OU"
8. After the photocell is activated, the digital display will show 1S "PH"
9. After the PED mode is activated, the digital display will show 1S "PD"
10. After the motor protection is activated, the digital display will show 1S "OH"

8.How to Program or Erase the Remote

The remote MUST be programed to the opener BEFORE OPERATING. Please follow the steps to program the remote.

Activate the opener only when gate is in full view, free of obstruction and properly adjusted. No one should enter or leave gate area while gate is in motion. DO NOT ALLOW CHILDREN to operate push button or remote. DO NOT ALLOW CHILDREN TO PLAY NEAR THE GATE.

Lamp function	When the gate is moving, the lamp will light on; when the gate is stop moving, the lamp will turn off. When the gate is on the auto-close countdown state, the lamp also will light on.
Motor protection	As soon as the motor runs continuously for more than the 90s, the motor will automatically stop working to protect the motor. When the control board detects that the temperature of the motor drive module exceeds the threshold, it will immediately cut off the power supply of the motor, the digital display will show "OH", and the system is in an overheating protection state, and the motor cannot be controlled at this time. When the temperature drops to a certain level, the system will release the overheating protection state.
Smart module (optional)	<ol style="list-style-type: none"> 1. Program the 2.4G transmitter: Short press the DEC/Smart button, the buzzer will sound once, smart indicator LED will light on, enter the programming mode. Transmit the 2.4G signal, if the indicator LED flash twice and keep lighting on, which means the programming is successful. Otherwise, after 8s will exit the programming mode automatically. 2. 2.4G control mode: while the mode received the 2.4G signal, it will open the gate once. 3. Add the bluetooth device: Open the XHouse IOT app, enter the add device mode, and choose the bluetooth device. Choose the correct bluetooth device, press the add button. (The bluetooth device mode number is XHOUSE_092BLE_XXXXXX, XXXXXX is its serial number). 4. Bluetooth device control mode: On the app, there has three buttons, including open, close and stop. 5. Initialize the bluetooth device: Hold press the 2.4G button about 5s, while you hear the buzzer sound two beep, release the button, the operation is complete. 6. Factory reset the bluetooth device: Hold press the 2.4G button about 10s, while you hear the buzzer sound with a long beep, release the button. After that, the module will erase all the 2.4G transmitter and initialize the bluetooth device.

7. Digital Display Setting

- ◆ Press and hold the [FUN] button for 3 seconds, and the digital display will indicate "P0", then release the button, now the menu can be set to [INC/START] and [DEC/SMART] for increasing and decreasing numbers or values.
- ◆ After adjusting the value, press the [FUN] button to store the data, and the buzzer will beep one time to show the store successfully.
- ◆ After the menu setting is finished, press the [LEARN] button to exit the menu setting and close the display.

3. Installation Overview

3.1 Gate Opening Default Setting Information

The gate motor will open the gate to the right-hand side as its default setting (Refer to diagram 2).

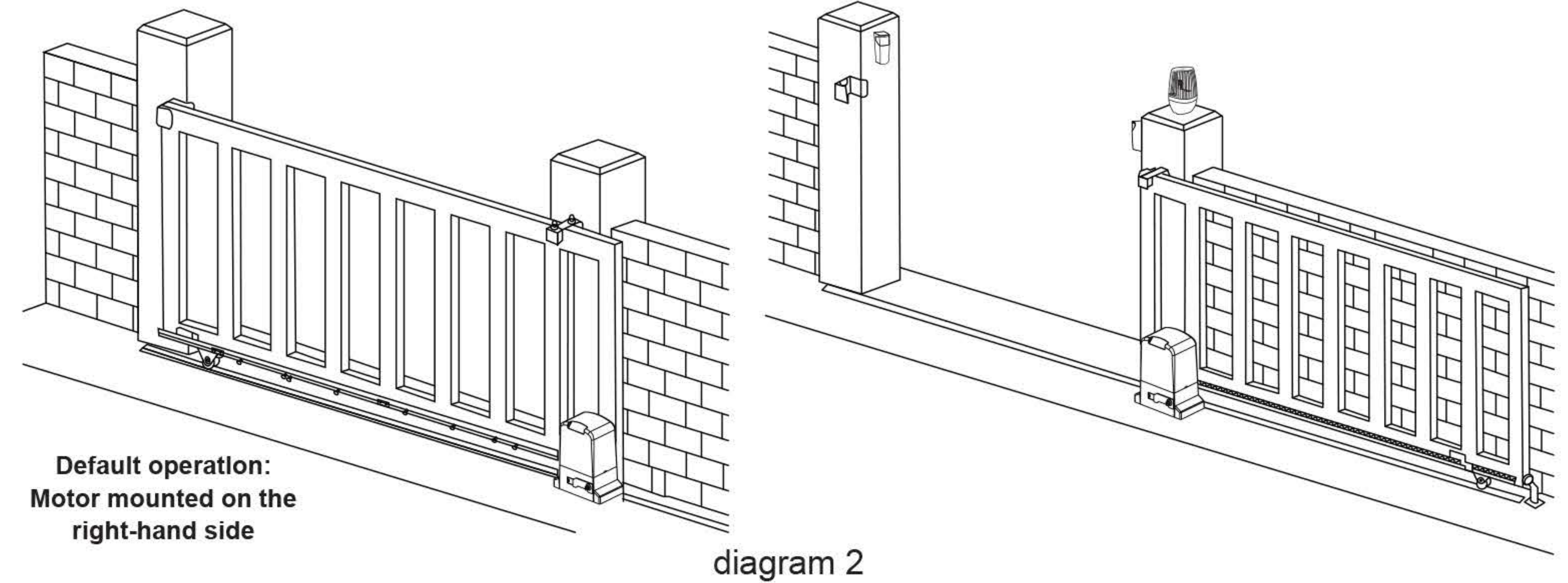

If your gate needs to open from the other direction (to the left, refer to diagram 3) your motor needs to be mounted on the left-hand side as shown, you will need to switch 2 wires of motor (diagram 8) at random.

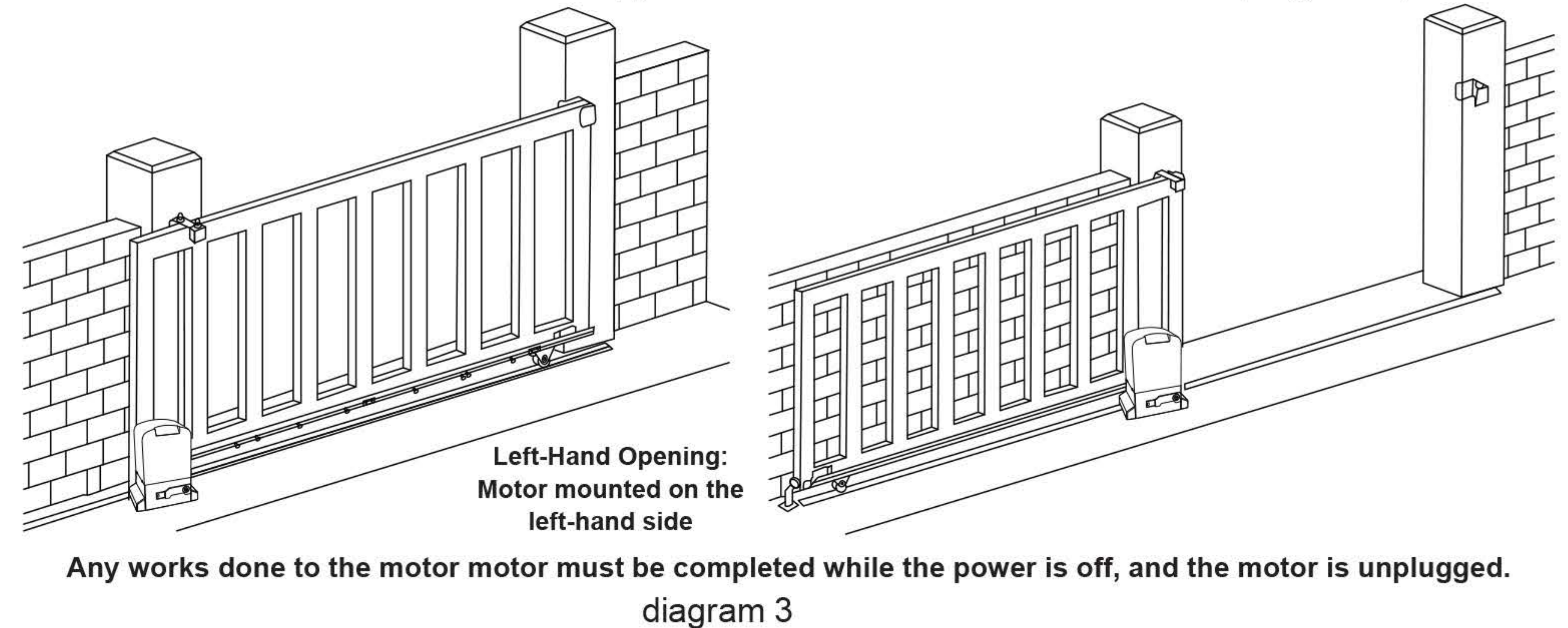

3.2 Install the motor

• Installation of motor base plate

1. Depending on the installation size of the motor and mounting height of racks, after determine the installation position of the motor base plate, first let the bolt embedded or use expansion bolt to make base plate fixed on watering good cement foundation. See diagram 4.

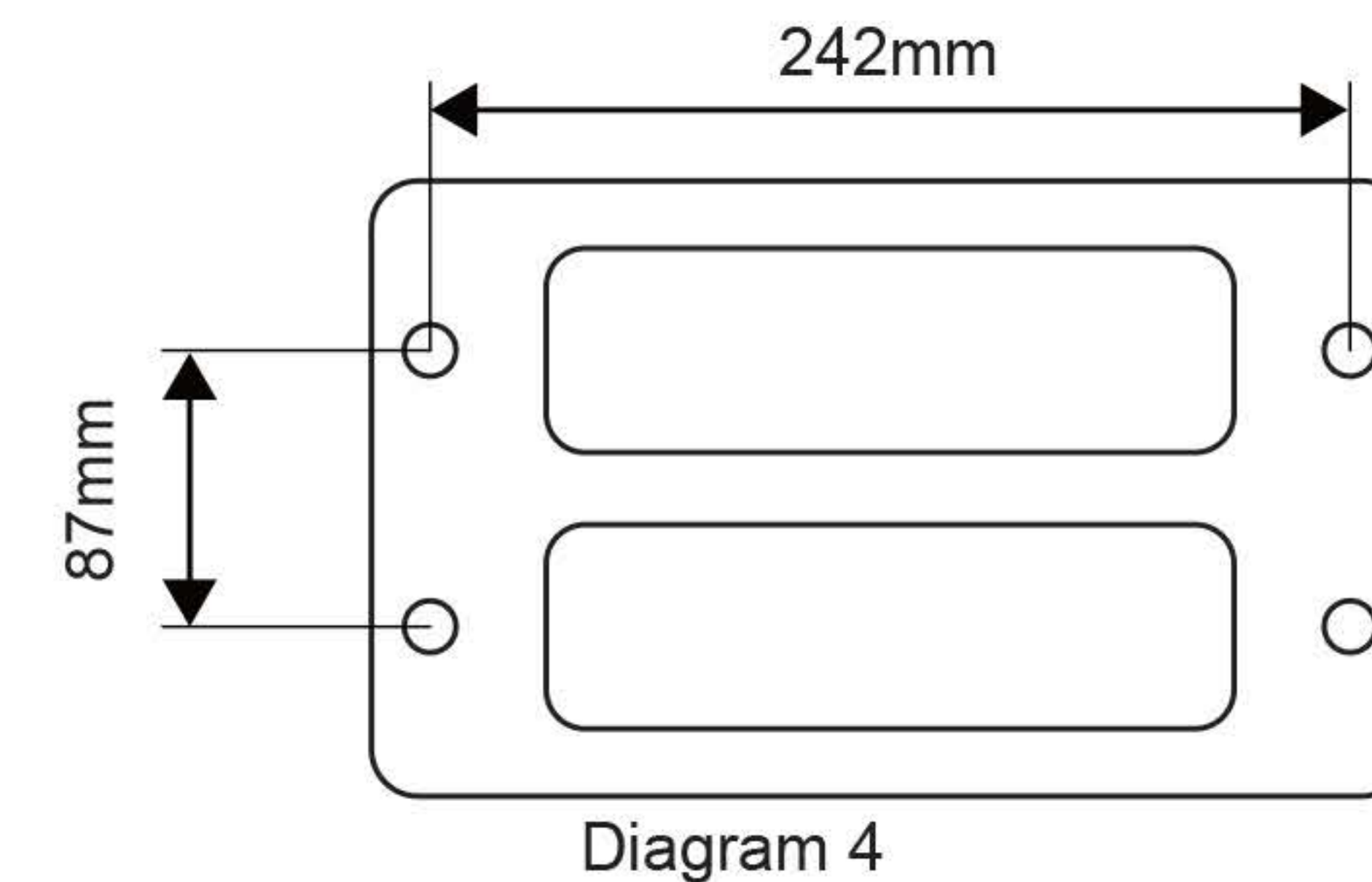

2. If gear rack has been installed on door, motor can be fixed on it, use a allen key rotation to clutch "off" position, after motor gear and gear rack match well to determine position of base plate, then remove motor and fix base plate.

• **Installation of gate opener**

1. Put gate opener on base plate, use a random matching hexagon screw make the motor fixed on the base plate.
2. Unscrew the screws fixed the motors cover, remove motor cover. According electrical wiring diagram, connected power cord, after adjust in good position, then install cover and use screws to fixed it.

• **Preparing for gear racks installation**

Using the supplied override key unlock the clutch and pull out manual override lever (see diagram 5) then manually close the gate.

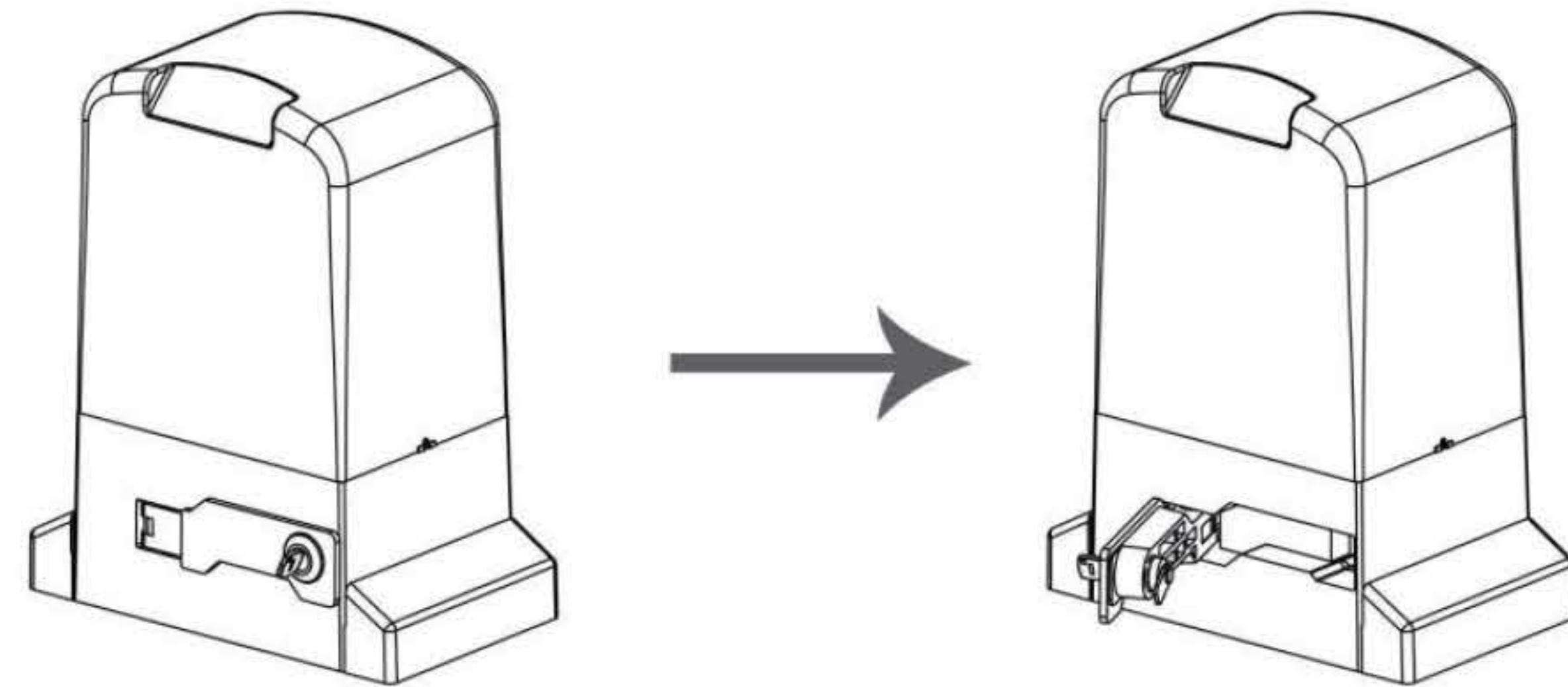

Insert Key, rotate 90 degrees
Diagram 5

Releasing arm in torsion, wriggle 90 degree
gate operator will be in releasing state

• **Install the gear rack on the gate**

Each piece of rack will interlock into the next piece (see diagram 6).

The best method for installation is to first close the gate using the manual override, sit the first piece on the gear of the motor (make sure it is 100% level first) then fix directly to the gate in the centre of the fixing hole of the rack. Now loosen the fixing and adjust the spacing between the motor gear and the gear rack (allow 2-3mm gap)

Re-tighten and fix the next remaining holes on the rack.

Move the gate manually forward and backward along the installed rack to ensure that the gap between the rack and the gear is consistent throughout.

Clip in the next piece of rack into the first (make sure it is 100% level first) then fix directly to the gate in the centre of the fixing hole of the rack.

Again move the gate manually forward and backward along the installed racks to ensure that the gap between the rack and the gear is consistent throughout. Repeat the above method to complete the racks installation and always be sure to move the gate manually forward and backward every time you install another piece of the rack.

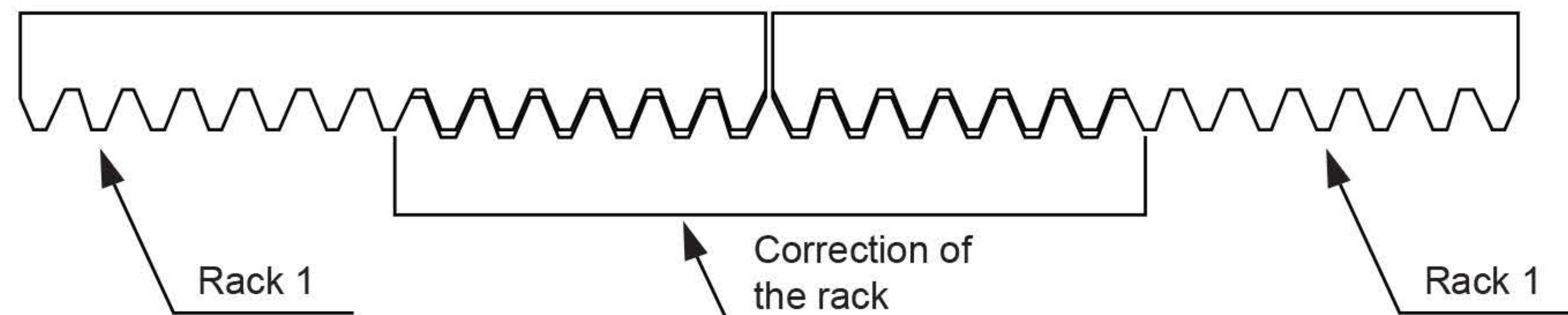
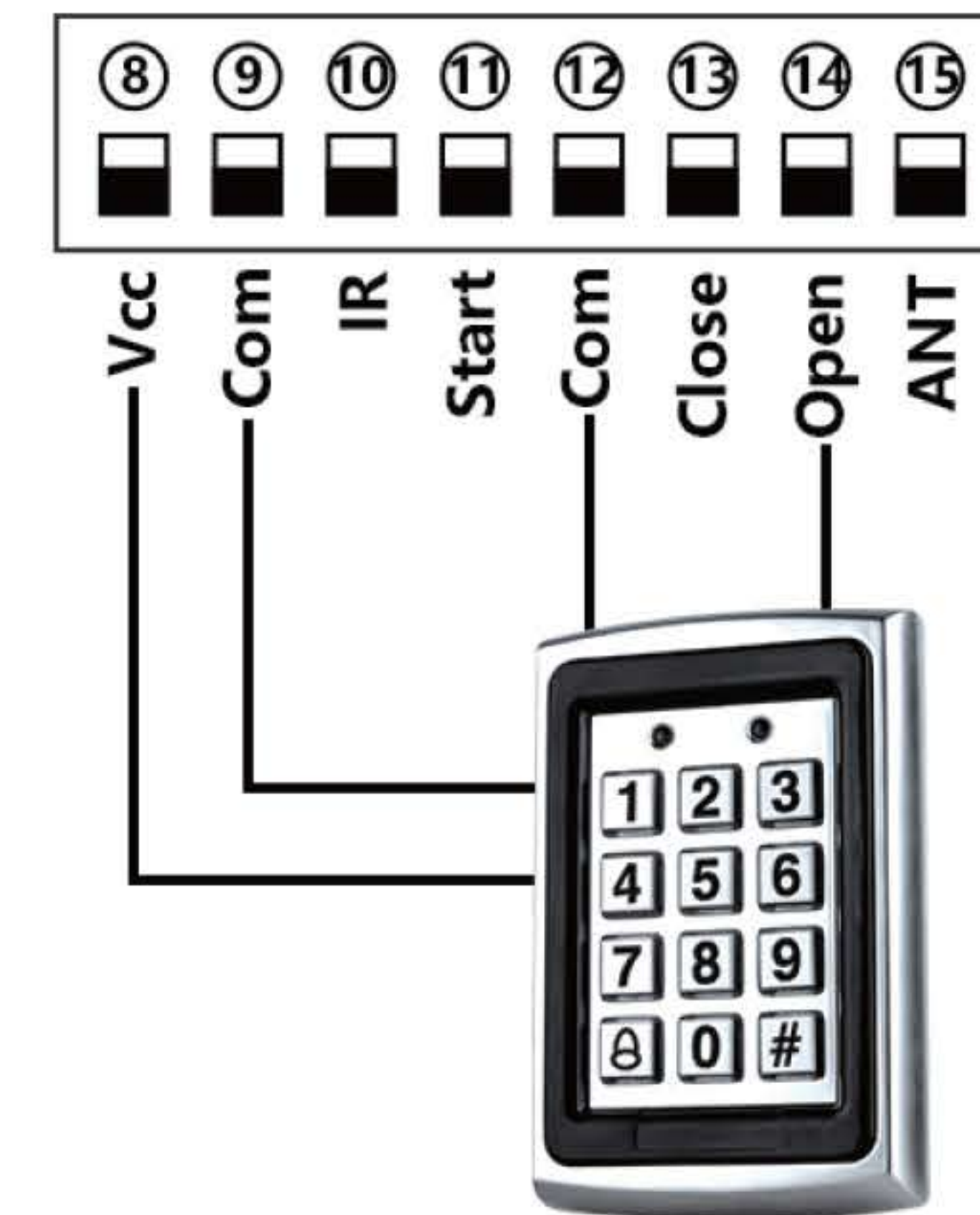

Diagram 6

• **Connect with open/close gate device**



Open gate device:

Terminal ⑧ and ⑨ is for supplying the power to the push button.

Terminal ⑪ and ⑫ is for connecting with the device.

Close gate device:

Terminal ⑧ and ⑨ is for supplying the power to the push button.

Terminal ⑬ and ⑭ is for connecting with the device.

6.Control board function description

Item	Description
Power on	After the control board powered on, the buzzer will sound, and the digital display will show model number and version, and the status 15 indicator LED lit up.
Resistance functions	The resistance function can achieve an anti-smashing car. While the gate motor is opening, it meets obstruction and will stop. If the gate motor is closing and meets the obstruction, the gate will be reopened. The motor's low-speed and high-speed running resistance sensitivity can be set through the digital display menu P0 and P1.
Limit function	While the gate moves to the open or close position, the motor will auto-stop running. The limit mode can be set through the digital display menu P7, has NC and NO mode for optional.
Infrared resistance function	While the gate is closing, if the infrared is triggered, the gate will rebound to open. When the gate is opening fully, after 3s, the gate will be auto-closed.
Auto close	The auto-closing function is only activated after the open limit switch is enabled. When auto-close start to countdown, the STATE LED will flash one time each second. Auto close time can be set through the digital display menu P6.
Pedestrian mode PED	The remote 4th button can trigger the PED mode. When user trigger the PED mode, the gate will be auto open; At the moment, if user also activate the auto close function, then the motor will enter auto close countdown and close gate after time end. While user activate the PED mode, the gate open time and auto close count down time can set through the digital display menu P4 and P5.

● Connect with flash lamp

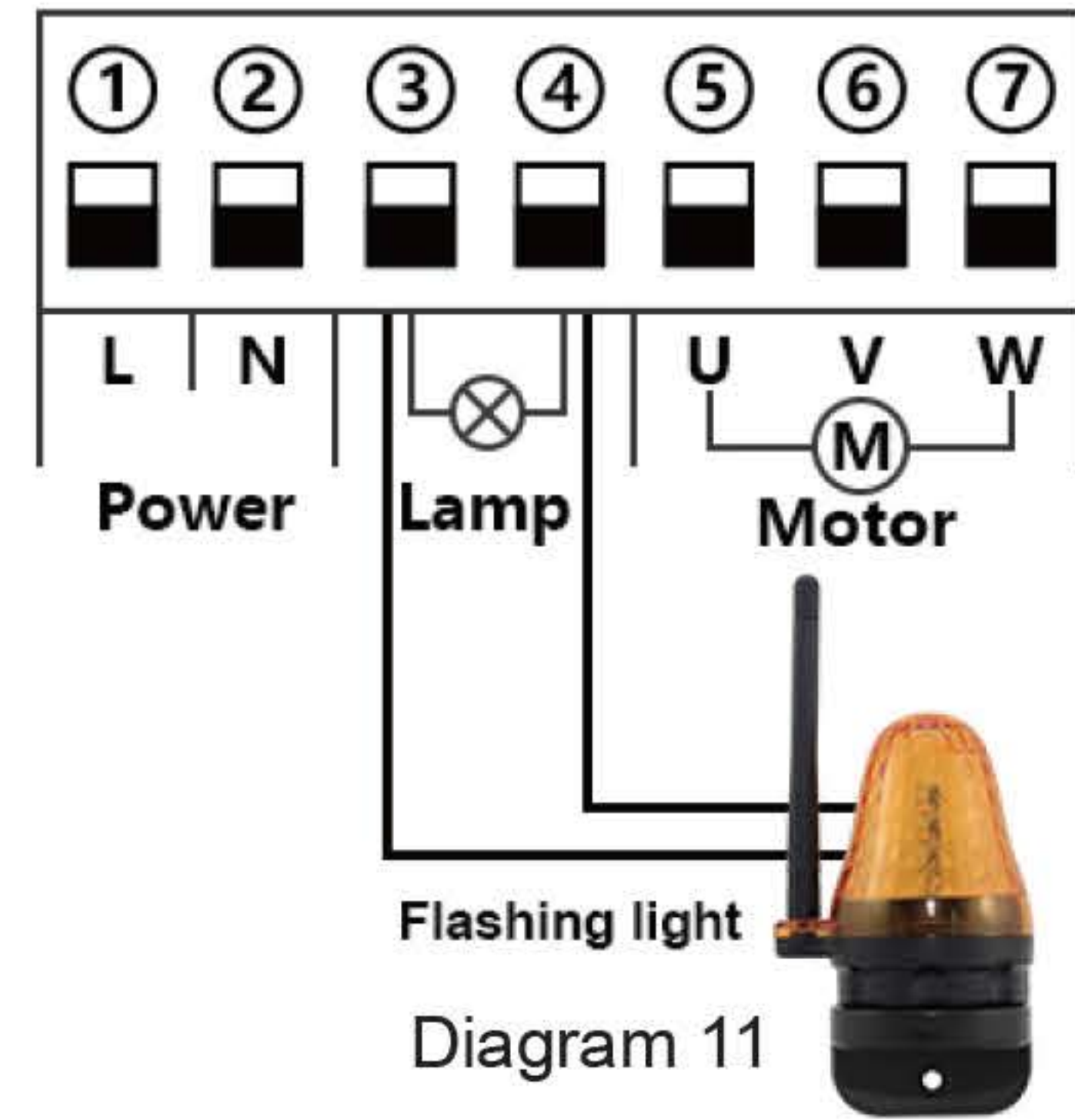

Diagram 11

Terminal ③ and ④ is for connecting with the flash lamp .

● Connect with photocell sensor

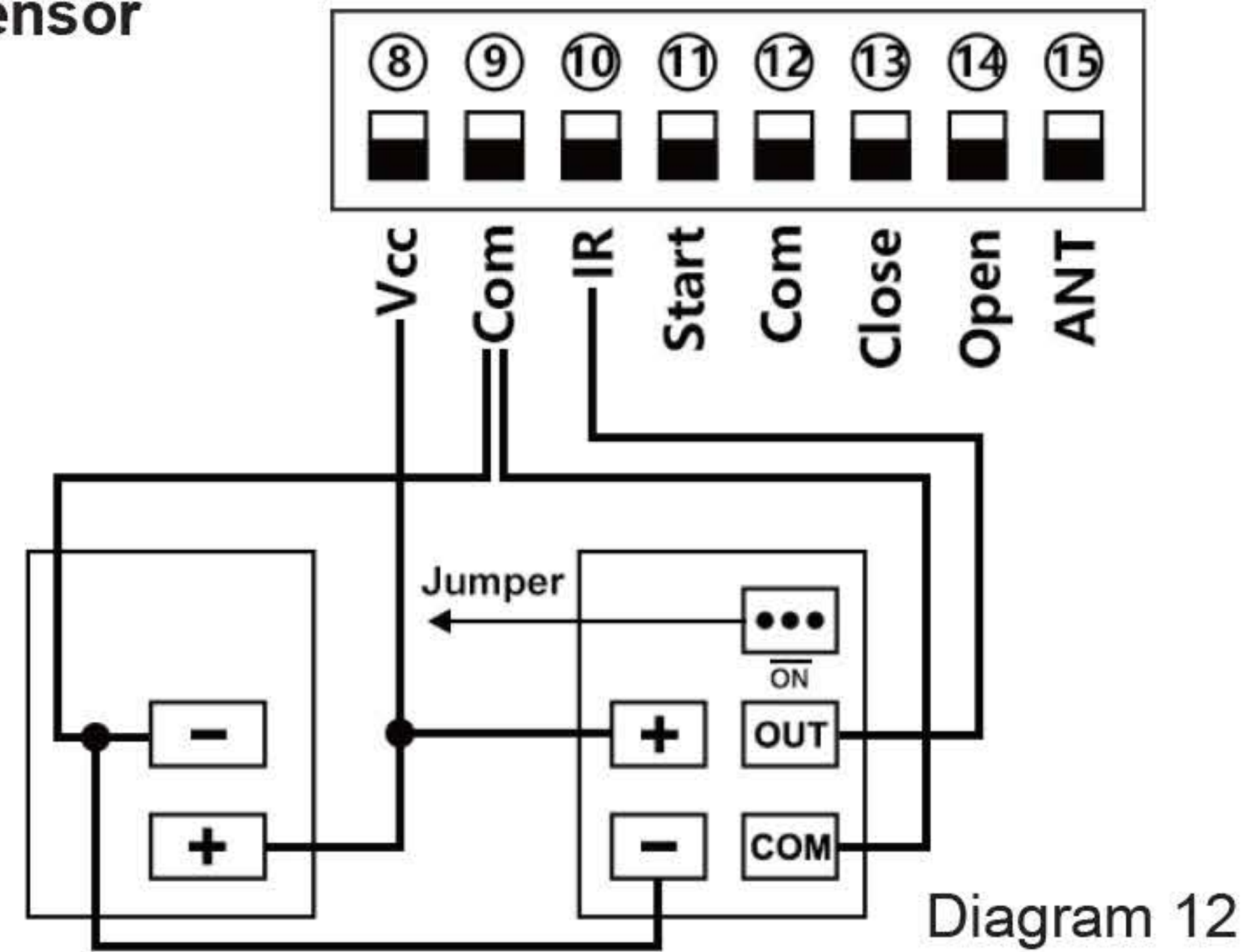

Diagram 12

Connect terminal ⑪ with the "COM " of photocell RX.
 Connect terminal ⑩ with the "OUT " of photocell RX.
 Connect terminal ⑧ with the "+ " of photocell RX and TX.
 Connect terminal ⑨ with the "- " of photocell RX and TX.

Please note: the sliding gate control board is factory set to connect NO model of photocell, So please keep the jumper on the NO, as picture DIAGRAM 11 show!

● Connect with Start terminal for "open-stop-close-stop-open" cycle controlling mode

Start terminal is used for connecting with some external devices , such push button, wired keypad, receiver etc. Control gate by " open-stop-close-stop-open " mode

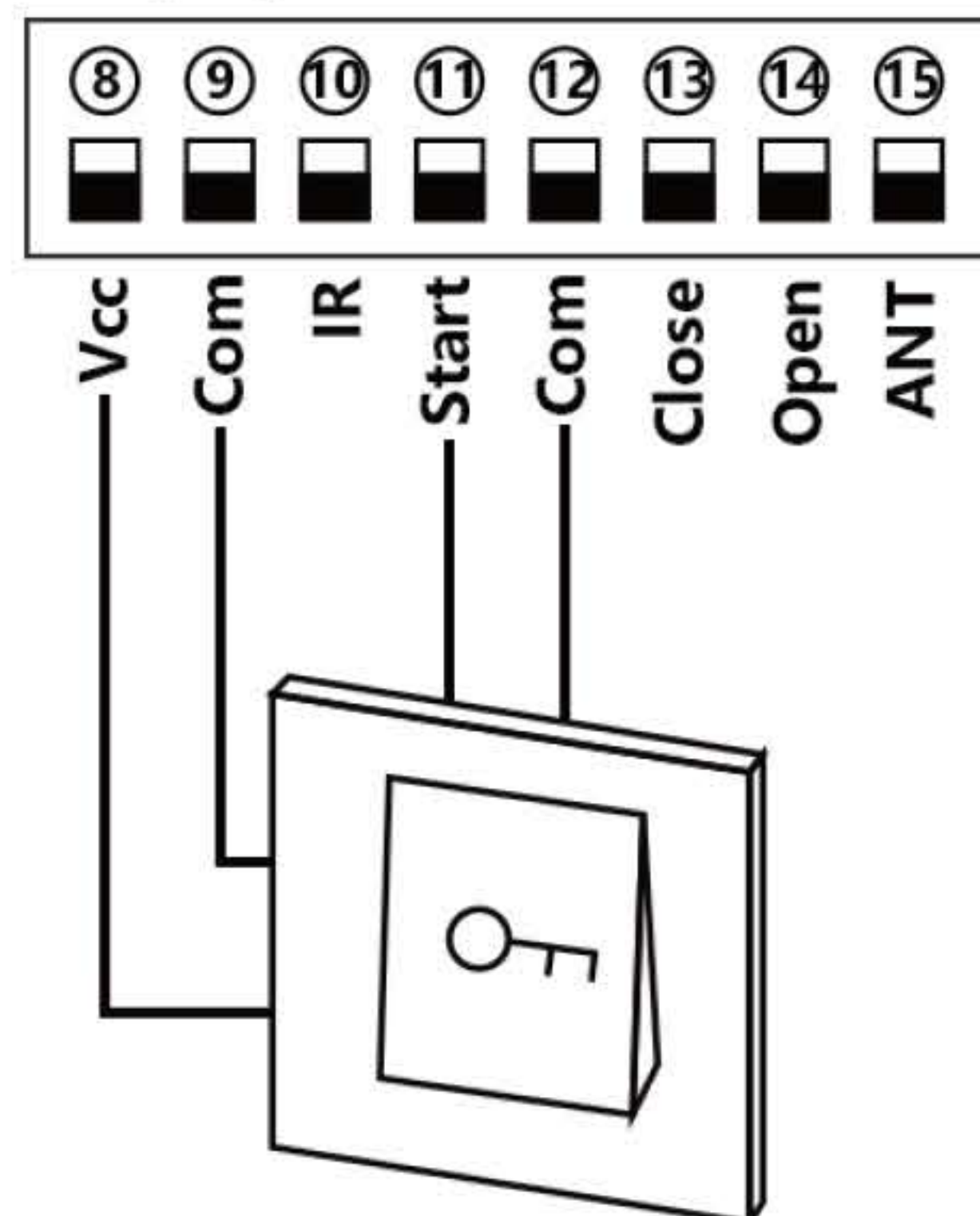

Terminal ⑧ and ⑨ is for supplying the power to the push button.
 Terminal ⑩ and ⑪ is for connecting with the push button.

The striker plates must be installed now to set the open and close positions for the motors operation. They are fixed onto the gear rack and should strike the limit switch spring on the motor to set the operating parameter (see diagram 7).

Using the manual override open the gate to the desired open position and install the open striker then close the gate to the desired position and install the closed striker (small adjustment afterwards may be necessary to achieve the best results when the motor is powered later).

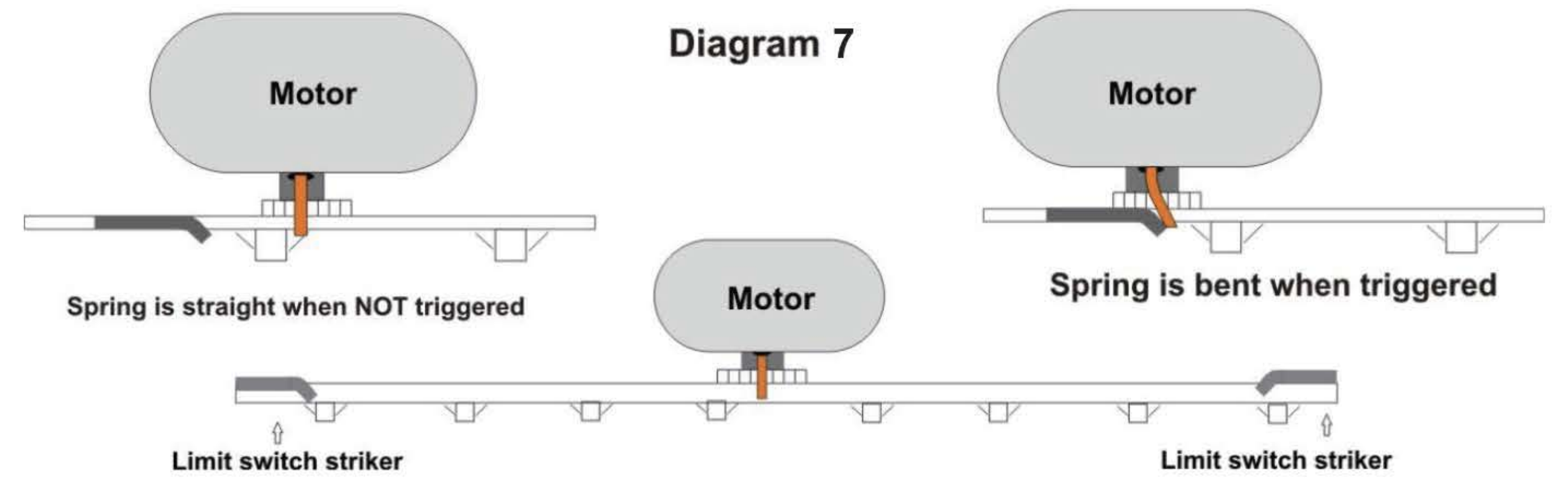

● Typical installation layout:

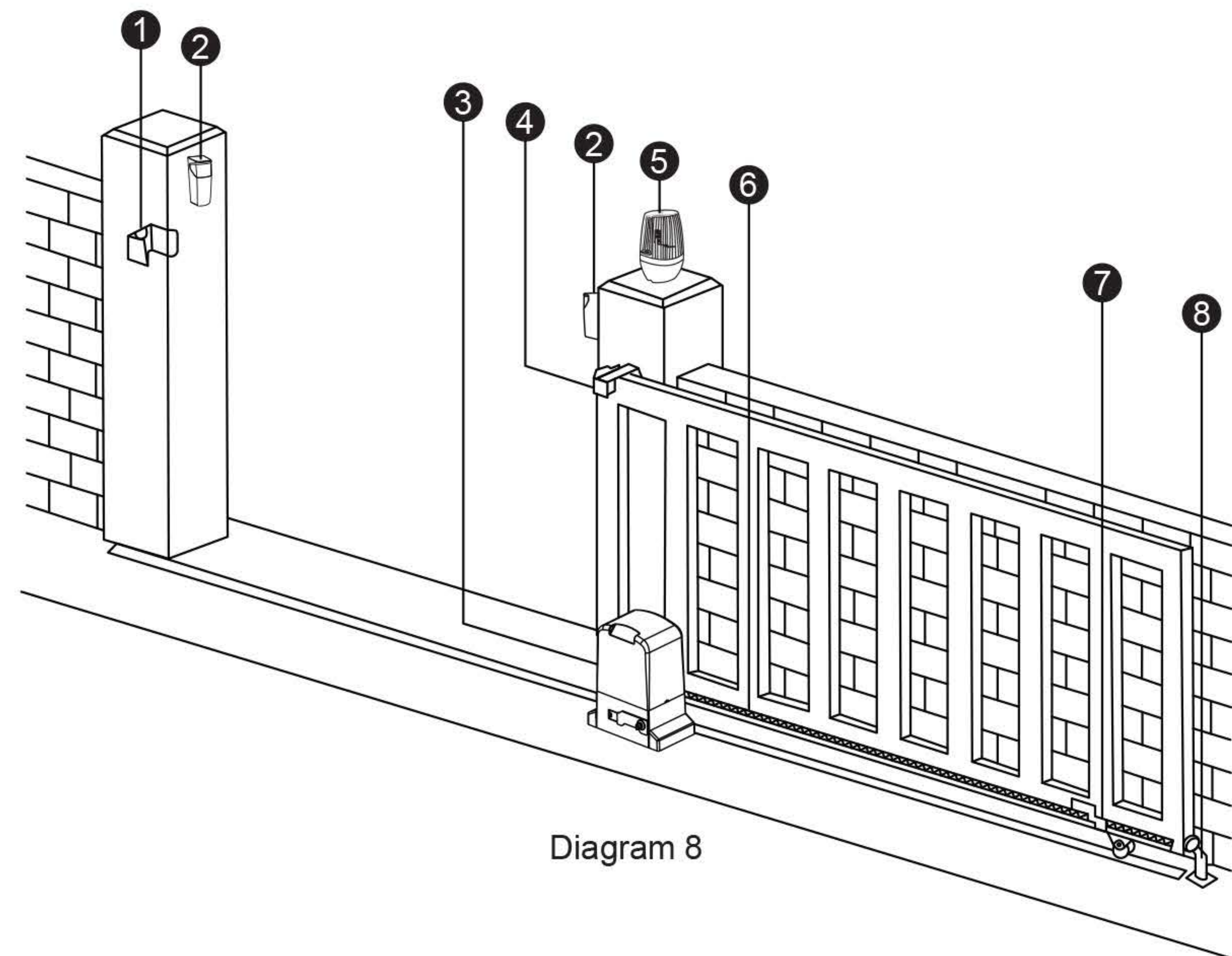

- ① Gate catch(optional)
- ② Photocell sensor(optional)
- ③ Gate motor
- ④ Gate roller(optional)
- ⑤ Flash lamp(optional)
- ⑥ Gear rack(optional)
- ⑦ Limit plate
- ⑧ Gate stopper(optional)

4. Connection of the Power Supply and Control board

WARNING! NEVER connect the gate opener to the power outlet before all the installations have been done.

Only use the AC electricity as the power source

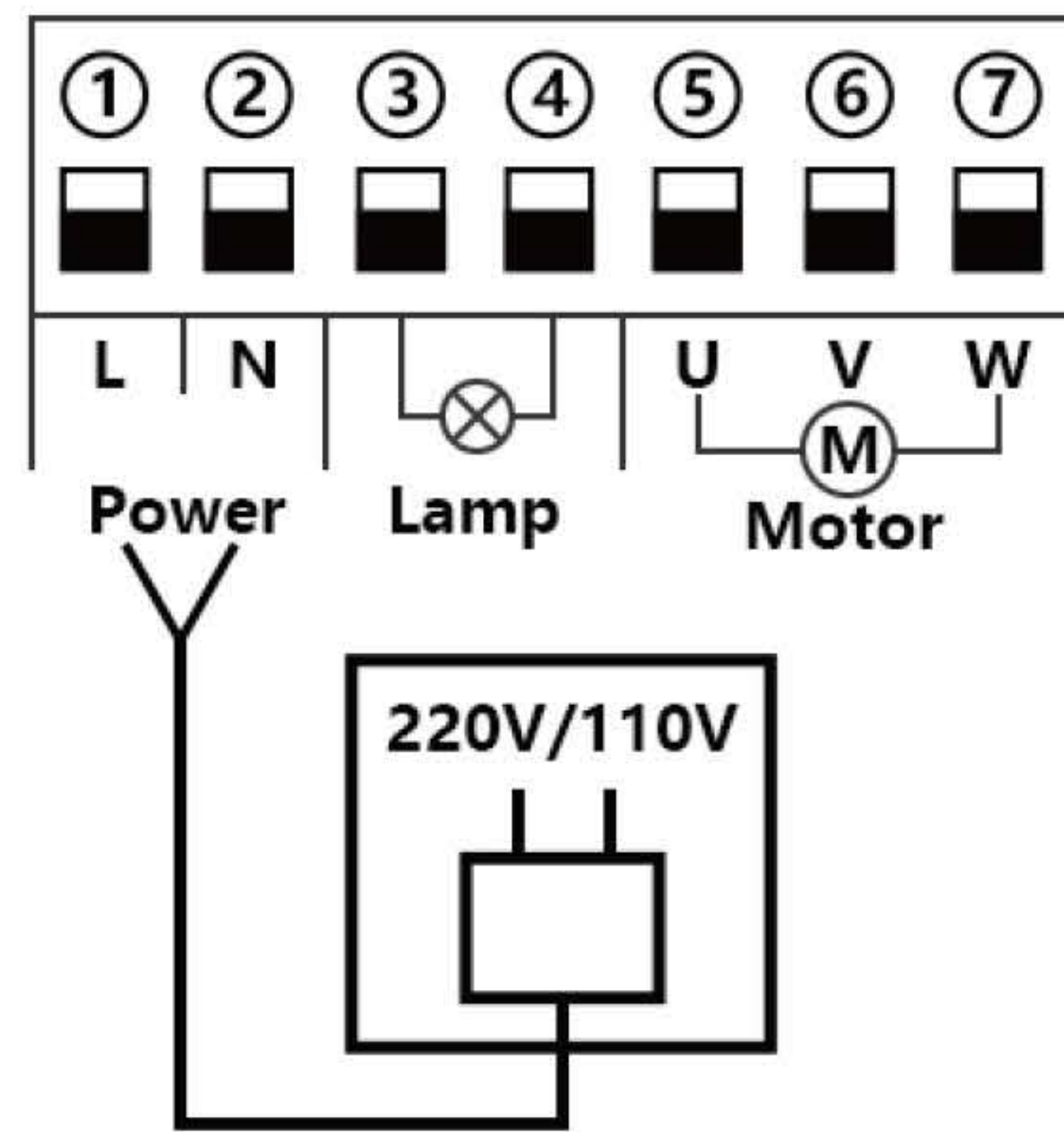

5. Connection of the Control Board

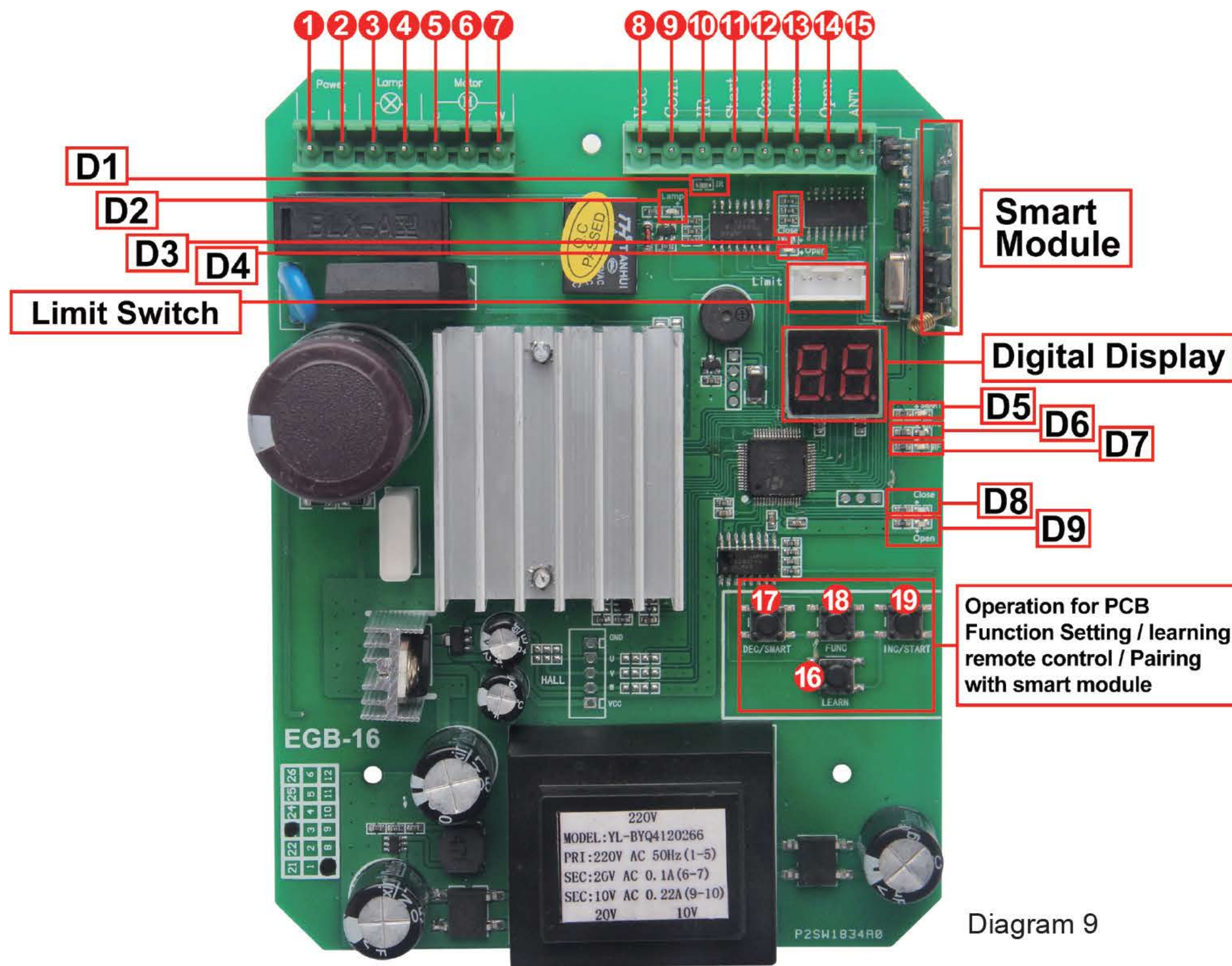

Diagram 9

The following functions refer to the picture control board layout.

- 1&2. Power: used for connecting with AC 220V power supply.
- 3&4. Lamp: used for connecting with flashing light, output voltage is AC 220V.
- 5&6&7. Motor: used for connecting with sliding gate motor's wire.
- 8.VCC: DC 12V output used for connecting with external devices, max 100mA.
- 9.COM: used for connecting with COM terminal or GND.
- 10.IR: used for connecting with the photocell sensor.
- 11.Start: It is a single button control mode switch for controlling the gate by "open - stop - close - stop - open" cyclically.
- 12.COM: used for connecting with COM terminal or GND.
- 13.Close: used for connecting with any external devices that will operate to close the gate.
- 14.Open: used for connecting with any external devices that will operate to open the gate.
- 15.ANT: antenna connection.
- 16.LEARN: It is for programming/removing the remote control.
- 17.DEC/SMART: It is for figure decreasing of setting the data and add intelligent device.
- 18.FUN: It is for storing data.
- 19.INC/START: It is for figure increasing of setting the data and setting the single button control mode.

Programming

- D1:** The photocell sensors output signal instructions
LED ON: Photocell sensors detection, if there have obstacle when closed the door, the motor will stop working. LED OFF: Photocell sensors detection, there is no obstacle.
- D2:** LED ON: Warning light on flashing.
- D3:** Limit switch of closing the door.
LED ON: The door is not completely closed
LED OFF: The door is completely closed
- D4:** Limit switch of opening the door.
LED ON: The door is completely opened
LED OFF: The door is not completely opened
- D5:** Indicate for operation of smart module
- D6:** LED ON: the board with power on
- D7:** Indicate for learning/Delete remote control
- D8:** LED ON: Gate on closing
- D9:** LED ON: Gate on opening
- Connect with motor

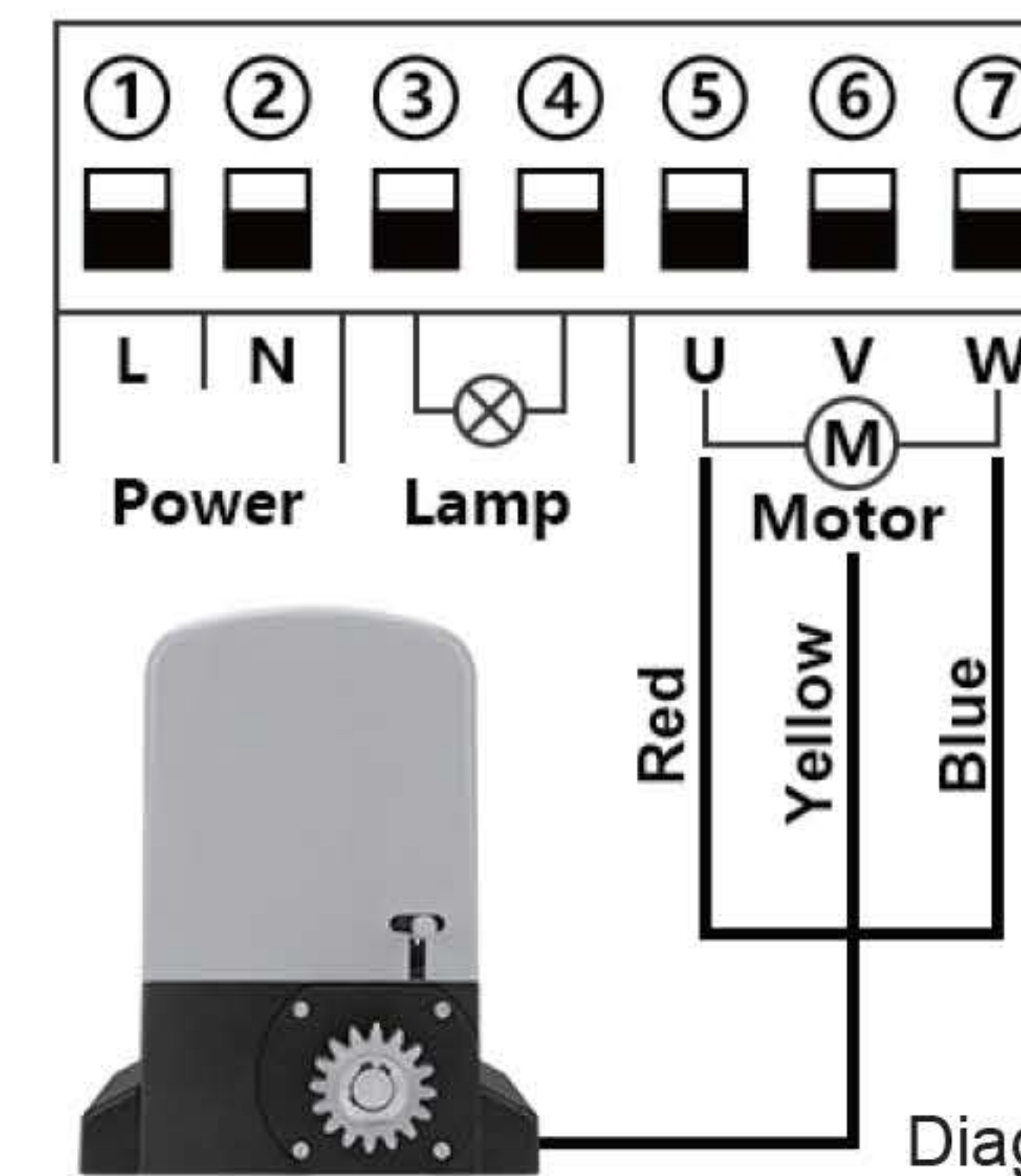

Diagram 10

Terminal ⑤, ⑥ and ⑦ is for connecting with the motor.