

# ROLLER-SHUTTER OPERATORS

# Company Profile



1986



1990



1995

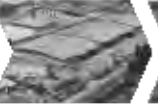

1999



Centurion Systems  
today

**In-house  
R & D  
development  
team**



**Manufacture to  
international  
quality standard  
ISO 9001:2008**



**100%  
testing of  
products**



**Competent  
after-sales  
technical support**



**Sales and support throughout  
Southern Africa and over  
50 countries worldwide**

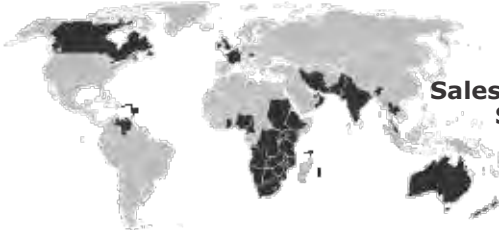

CENTURION SYSTEMS (Pty) Ltd reserves the right to make changes to the products described in this manual without notice and without obligation of CENTURION SYSTEMS (Pty) Ltd to notify any persons of any such revisions or changes. Additionally, CENTURION SYSTEMS (Pty) Ltd makes no representations or warranties with respect to this manual. No part of this document may be copied, stored in a retrieval system or transmitted in any form or by any means electronic, mechanical, optical or photographic, without the express prior written consent of CENTURION SYSTEMS (Pty) Ltd

# Contents



Mechanical Setup	Page 1
Electrical Setup	Page 1
Commissioning and Handover	Page 2



<b>IMPORTANT SAFETY INSTRUCTIONS</b>	Page 3
--------------------------------------	--------

1. Declaration of conformity	Page 6
2. Icons used in this booklet	Page 7
3. General description	Page 8
4. Specifications	Page 9
Physical dimensions	Page 9
Technical specifications	Page 9
5. Determining shutter weight and profile	Page 10
Roller-shutters with perforated profiles	Page 10
Roller-shutters with flat blind steel profiles	Page 11
6. Product identification	Page 13
7. Description of terminal functions	Page 17
Opening the enclosure	Page 17
Motor controller for <b>RSO5</b> only	Page 18
Interface board for <b>RSO5</b> only	Page 19
<b>RSO5DC</b> controller	Page 22
8. Required tools and equipment	Page 25
9. Preparation of site	Page 26
General considerations for the installation	Page 27
10. Cabling requirements	Page 27
<b>RSO5DC</b> cabling requirements	Page 28
11. Installation procedure	Page 29
Retrofit installations	Page 29
12. Electrical setup	Page 32
Secure wall pendant	Page 32
Connect all wiring	Page 32
<b>RSO5DC</b> connection and wiring	Page 33
<b>RSO5DC</b> menu navigation map	Page 36
<b>RSO5DC</b> controller features	Page 39
<b>RSO5DC</b> diagnostic LEDs	Page 51
<b>RSO5DC</b> Roller-shutter status LED	Page 51
<b>RSO5DC</b> LCD display	Page 52
<b>RSO5DC</b> buzzer feedback	Page 53

<b>RSO5DC</b> factory defaults schedule	Page 54
Power connections	Page 56
13. Setting the travel limits	Page 57
The limit switch assembly	Page 57
<b>RSO5, RSO5R, RSO5RE</b> and <b>RSO5R3P</b>	Page 58
<b>RSO5DC</b>	Page 58
<b>RSO9</b>	Page 60
14. Connecting an external radio receiver	Page 61
15. Connecting infrared beams	Page 62
16. <b>RSO5DC</b> wiring diagram for other inputs	Page 64
17. Manual operation	Page 65
18. Installation handover	Page 66



# Mechanical setup

These abbreviated instructions are for the experienced installer who needs a checklist to get a standard installation up and running in the minimum of time.

Detailed installation features and functions are referred to later in this manual.

These abbreviated instructions are for the experienced installer who needs a checklist to get a standard installation up and running in the minimum of time.

Detailed installation features and functions are referred to later in this manual.



Heed necessary site considerations Page 24



Check cabling requirements Page 25



Gather required tools and equipment Page 24



Retrofit installations Page 27



Setting the travel limits Page 55

# Electrical setup



Electrical setup Page 60



Connect all wiring page 24



# Commissioning and handover



Setting the travel limits

Page 55



Connecting an external radio receiver and infrared beams

Page 59



Manual operation

Page 63



Installation handover

Page 64

**FAST TRACK**





# IMPORTANT Safety Instructions

## ATTENTION

To ensure the safety of people, it is important that you read all the following instructions. Incorrect installation or incorrect use of the product could cause serious harm to people.



The installer, being either professional or DIY, is the last person on the site who can ensure that the operator is safely installed, and that the whole system can be operated safely.

## Warnings for the installer

### CAREFULLY READ AND FOLLOW ALL INSTRUCTIONS

before beginning to install the product.

- The installation of your new Roller-shutter Operator (herein after referred to as '**RSO**') must be carried out by a technically qualified or licensed person. Attempting to install your new **RSO** without suitable technical qualification may result in severe personal injury, death and/or property damage
- Only install the **RSO** on a properly balanced and aligned, well functioning shutter (or 'curtain', as it is more commonly known). An improperly balanced or malfunctioning curtain could cause serious injury. Have a qualified person check and, if required, make repairs to your curtain before installing the **RSO**. As a general rule, your curtain is deemed to be well balanced and aligned if it:
  - Requires an equivalent amount of applied force to manually open and close,
  - Does not rise or fall more than 100mm when stopped at any position between fully open and fully closed positions, and
  - Does not rub or make contact with any supporting or surrounding structures
- Repairs to roller-shutters must only be carried out by technically qualified persons. Attempting to repair the system without suitable technical qualification may result in severe personal injury, death and/or property damage.
- Remove or render inoperative all existing locks and ropes prior to installation of the **RSO**

- The helical coil springs must be properly lubricated between all of the coils with heavy automotive bearing grease. Failure to adequately lubricate the springs may result in one or more of the following symptoms;
  - The springs will become rusty over time resulting in extra operating friction between the coils which may cause the **RSO** to malfunction
  - Seasonal temperature changes may cause the roller-shutter springs to expand and/or contract. The resultant increase and/or decrease in operating friction may cause the **RSO** to malfunction. Properly lubricating the springs will help to minimise the effects of seasonal temperature changes in operating friction of your roller-shutter
- It is recommended that the manual operation chain is housed within the chain bag included with this kit and positioned in such a way that only authorised users have access to it, so as not to compromise the security of the installation.
- Do not connect the **RSO** to the power source until this manual instructs you to do so or if safe
- The **RSO** must be connected to a properly earthed general purpose 220V (380V for certain models) outlet which has been installed by a qualified electrical contractor
- Locate the wall control/pushbutton:
  - Within site of the curtain and,
  - At a minimum height of 1.5 meters above the ground so that it remains out of reach of small children and,
  - Away from all moving parts of the door
- Install warning decals in a prominent position next to the wall control button
- Never use the **RSO** unless the curtain is in full view and free from objects such as cars, children and/or adults
- Never allow children to operate the **RSO**
- Never operate the **RSO** when children/persons are under or near the path of the door. Children must be supervised at all times when near the curtain and when the **RSO** is in use
- Never attempt to disengage the **RSO** to manual operation when there are persons and/or other objects including motor vehicles under or near the path of the curtain
- Never attempt to make any repairs or remove covers from the **RSO** without first disconnecting the power supply cord from the main power supply
- For additional safety we strongly recommend the fitment of safety beams on the **RSO** models that allow for them, i.e. the **RSO5** and **RSO5DC**. The addition of safety beams will greatly enhance the operating safety of the **RSO** and provide additional peace of mind.





In some countries it is mandatory and required by law to fit safety beams

- It is the sole responsibility of the owner/installer to fit safety beams in those countries that so require
- Removal of the **RSO's** protective covers must only be performed by a technically qualified person. Attempting to remove the protective covers or repair the **RSO** without suitable technical qualification may result in severe personal injury, death and/or property damage
- Always ensure that the curtain is fully open before driving into or out of the building
- Always ensure that the curtain is fully closed before leaving the driveway
- Keep hands and loose clothing clear of the curtain and product at all times
- As the **RSO** is often installed at great heights, ensure that the necessary scaffolding and safety harnesses are employed and that they are stable and secure
- NEVER PULL THE MANUAL RELEASE PIN IF A PERSON OR OBJECT IS DIRECTLY UNDERNEATH THE CURTAIN

**Everything not expressly specified in these instructions is not permitted.**



# 1. Section left intentionally blank

Please note that this page has been left blank intentionally, and will be updated in the near future

## 2. Icons used in this manual



This icon indicates tips and other information that could be useful during the installation



This icon denotes variations and other aspects that should be considered during installation



This icon indicates warning, caution or attention! Please take special note of critical aspects that **MUST** be adhered to in order to prevent injury

## 3. General description

The CENTURION Industrial **RSO** range has been designed to safely automate extremely heavy roller-shutter doors such as entrances to factories and loading bays.

There are six models available, each tailor-made to suit individual installation requirements. Each model is equipped with a heavy-duty electric motor that, coupled with a powerful gearbox, delivers maximum lifting force. In addition, a convenient manual override facility comprising a 5m chain ensures that the door can be operated even in the event of a power failure. A three-button wall pendant allows the operator to not only open and close the door but also safely stop it should an emergency situation arise. In addition, the **RSO5** and **RSO5DC** models also allow for the integration of radio receivers, meaning that the door can be operated remotely by means of a hand-held transmitter.

End-of-travel limits are managed by two normally-open limit switches, one for each direction of travel. Therefore there is no need for any unsightly additions to the roller-shutter structure.

The following six models are available:

### **RSO5R**

The **RSO5R** is ideal for sites requiring simple, cost-effective automation of doors weighing up to 500 kilograms. A three-button wall pendant is used to operate the door, with two normally-open pushbuttons for directional operation and one normally-closed pushbutton used to stop the door.

### **RSO5RE**

The **RSO5RE** is an endurance model ideal for high volume applications. The vastly improved duty cycle and high number of possible daily operations are made possible by a ventilated planetary gearbox.

### **RSO5R3P**

This is a powerful three-phase, 380V operator capable of delivering greater starting thrust than single-phase operators, and also boasts an increased duty cycle.

### **RSO5**

The **RSO5** utilises a powerful AC motor to lift doors weighing up to 500 kilograms and a multi-faceted interface board allows for the connection of safety beams, radio receivers, keypads, proximity access systems, etc.

### **RSO5DC**

The **RSO5DC** incorporates an intelligent logic controller complete with user-friendly LCD interface for easy setup. In addition, two 7Ah batteries provide reliable battery backup, ensuring that the **RSO5DC** remains in operation even in the event of a lengthy power outage. The controller also makes provision for the connection of ancillary items such as infrared safety beams, proximity readers and keypads.

### **RSO9**

The **RSO9** is a heavy duty model utilising a 380V, three-phase power supply enabling it to lift very heavy roller-shutter doors weighing up to 900 kilograms.

## 4. Specifications

### Physical dimensions

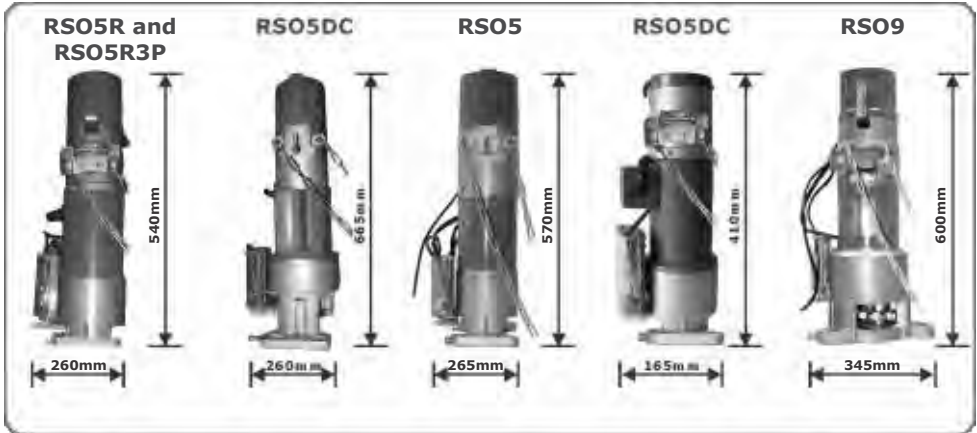

FIGURE 1. OVERALL DIMENSIONS

### Technical specifications

	RSO5R	RSO5R3P	RSO5RE	RSO5	RSO5DC	RSO9
Supply voltage	220V - 240V AC 50Hz	380V AC 3Ø 50Hz	220V - 240V AC 50Hz	220V - 240V AC 50Hz	220V - 240V AC 50Hz	380V AC 3Ø 50Hz
Power	360W	360W	375W	360W	220W	550W
Motor speed	1780rpm	1780rpm	1780rpm	1780rpm	1440rpm	1780rpm
Current	3.5A 1Ø	2A 3Ø	3A	3.7A 1Ø	4.6A 1Ø	2.2A 3Ø
Temperature protector	95°C	70°C	125°C	105°C	70°C	115°C
Output shaft rotation	53rpm	35rpm	28rpm	35rpm	50rpm	17 rpm
Gear ratio	34:1	55:1	64:1	51:1	55:1	105:1
Material of gear box	Aluminium	Aluminium	Cast-iron	Aluminium	Aluminium	Aluminium
Sprocket	9T	9T	9T	9T	9T	10T
Chain	5/8 inches	5/8 inches	5/8 inches	5/8 inches	5/8 inches	1 inch
Length	540mm	540mm	530mm	570mm	410mm	600mm
Net weight	12.7kg	12.8kg	20.2kg	12.8kg	9.64kg	22.1kg
Gross weight	13.5kg	13.5kg	21kg	13.5kg	10.4kg	23.0kg
Packing dimensions	540mm x 260mm x 200mm	570mm x 265mm x 210mm	665mm x 260mm x 200mm	570mm x 265mm x 210mm	570mm x 265mm x 210mm	600mm x 345mm x 285mm
Door speed	140mm per second ±10%	100mm per second ±10%	74mm per second ±10%	100mm per second ±10%	140mm per second ±10%	45mm per second ±10%
Door weight	500kg	500kg	500kg	500kg	500kg	900kg

## 5. Determining shutter weight and profile

### Roller-shutters with perforated profiles

#### Profile A

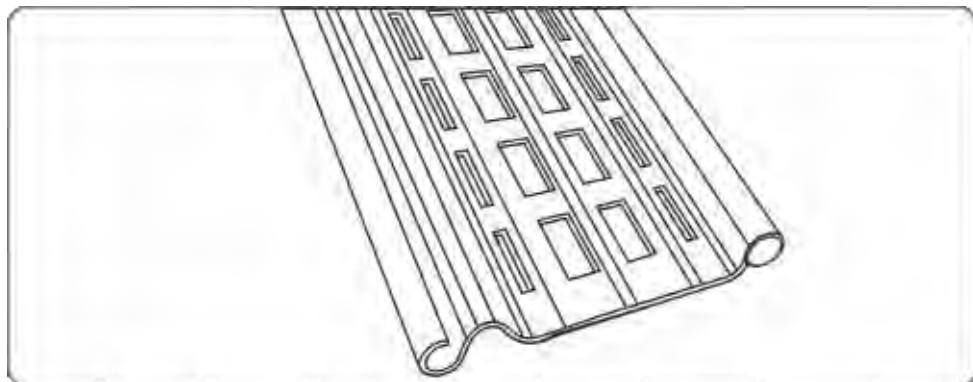

FIGURE 2. PROFILE A

Description	Size of interlocking sections	Thickness	Weight per square metre
Steel profile consisting of galvanised steel sheets	105mm	0.5mm	4.5kg

#### Profile B

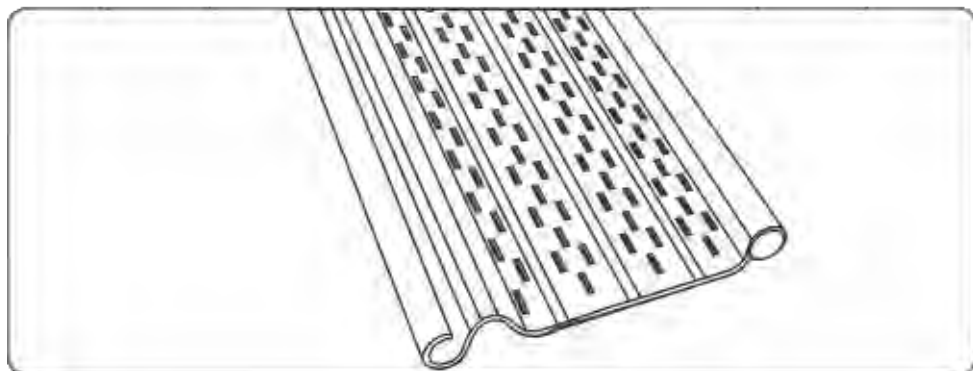

FIGURE 3. PROFILE B

Description	Size of interlocking sections	Thickness	Weight per square metre
Steel profile consisting of galvanised steel sheets with high-density micro-perforations of 4mm diameter	105mm	0.5mm	5.5kg
		0.7mm	7.7kg

## Profile C

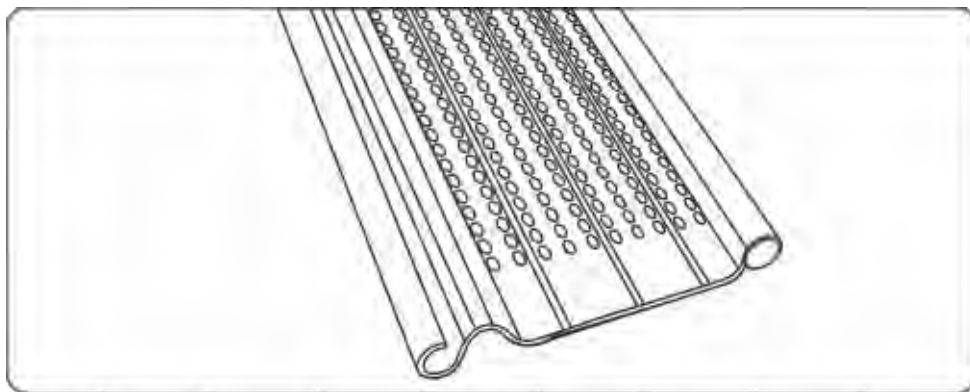

FIGURE 4. PROFILE C

Description	Size of interlocking sections	Thickness	Weight per square metre
Steel profile consisting of galvanised steel sheet with high-density micro-perforations of 2.5mm diameter	105mm	0.7mm	7.7kg

## Roller-shutters with flat blind steel profiles

### Profile D

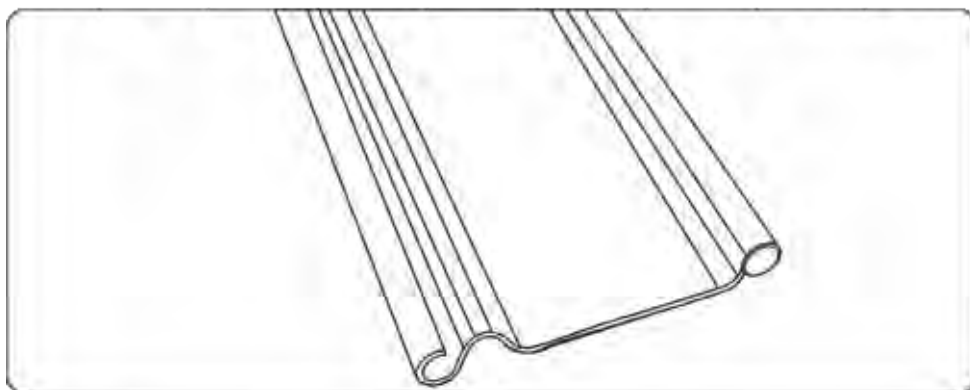

FIGURE 5. PROFILE D

Description	Size of interlocking sections	Thickness	Weight per square metre
Steel profile consisting of galvanised steel sheets	77mm	0.5mm	6.6kg

## Profile E

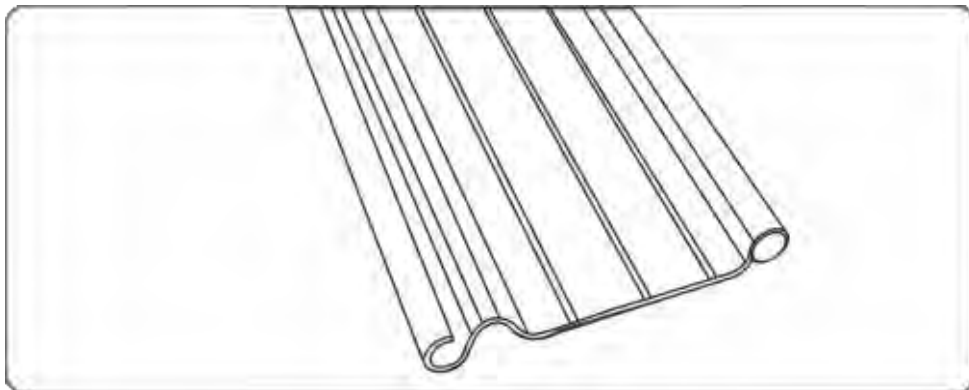

FIGURE 6. PROFILE E

Description	Size of interlocking sections	Thickness	Weight per square metre
Steel profile consisting of galvanised steel sheets	105mm	0.5mm	6kg
		0.7mm	8.4kg
		0.8mm	9.6kg



## 6. Product identification

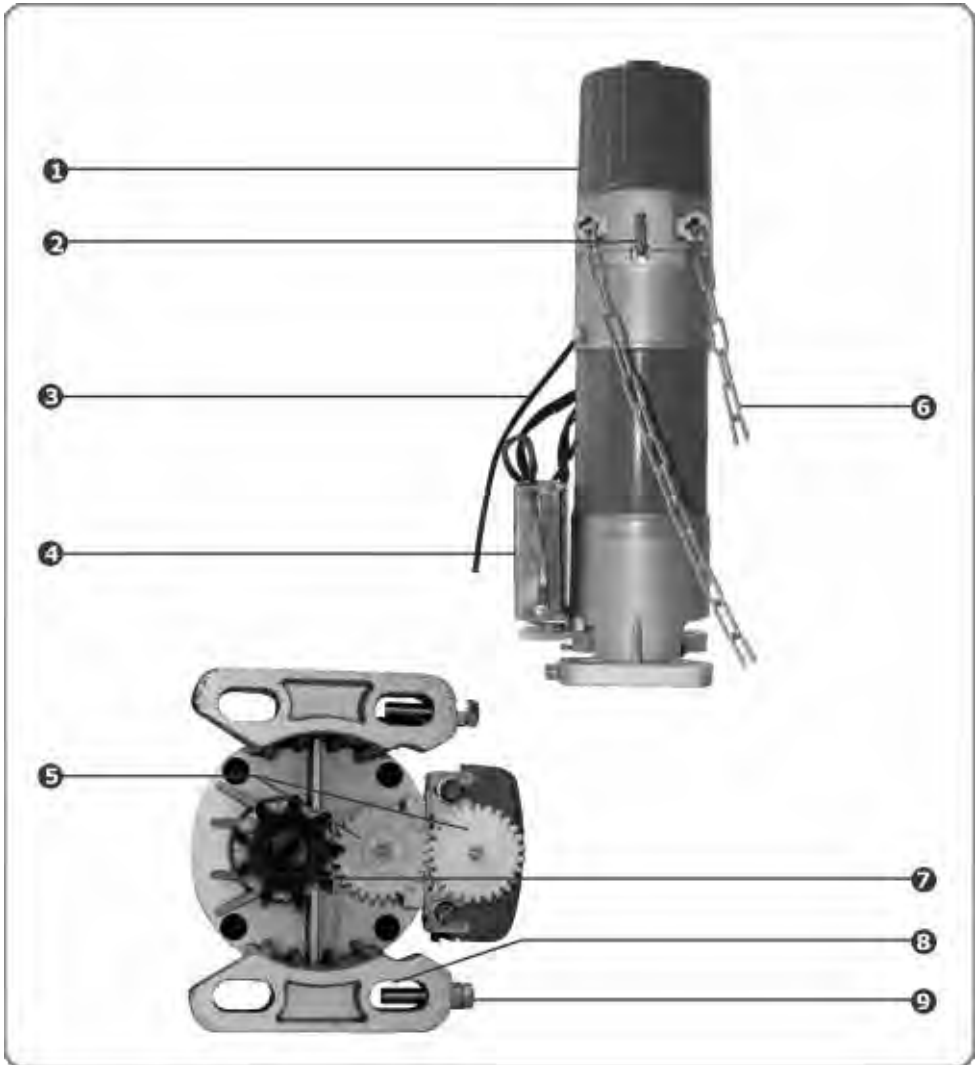
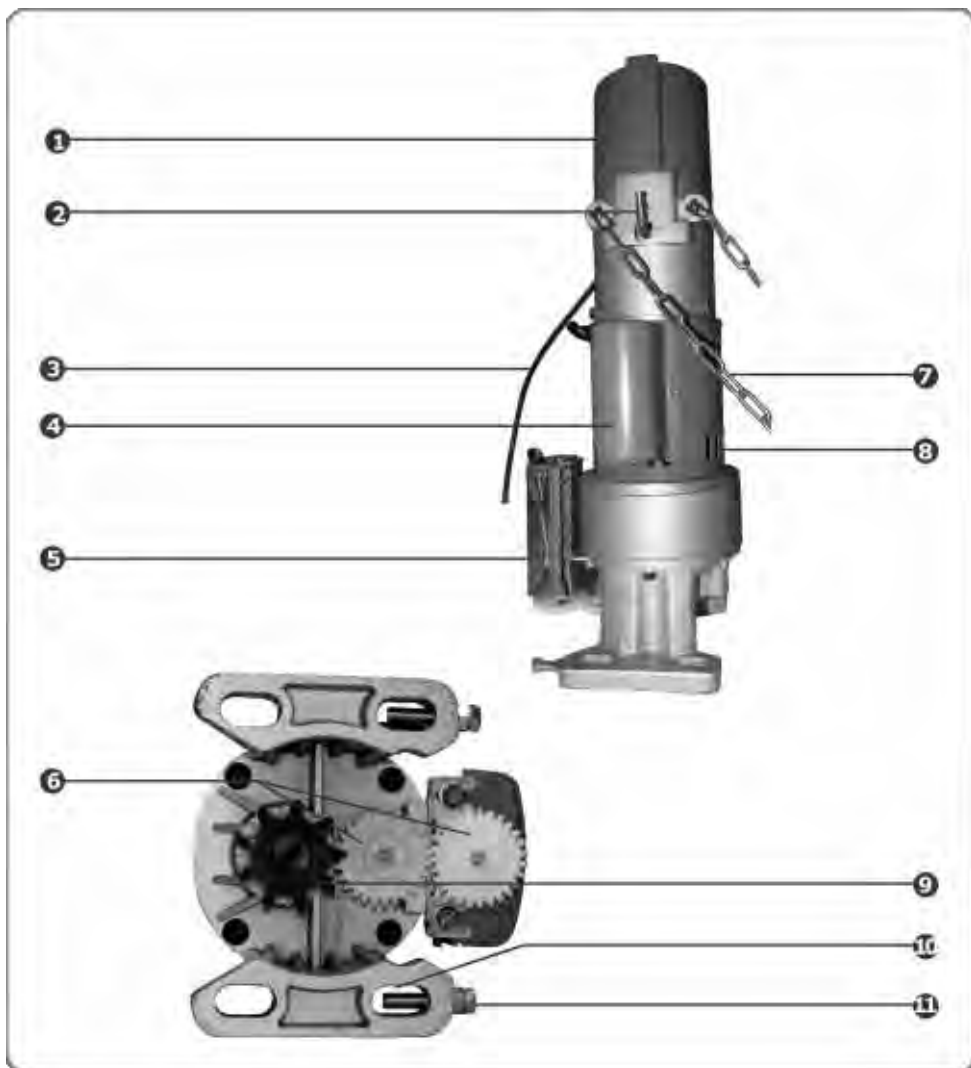

FIGURE 7. PRODUCT IDENTIFICATION RSO5, RSO5R and RSO5R3P

- |                         |                           |
|-------------------------|---------------------------|
| 1. Relay/PCB housing    | 6. Manual operation chain |
| 2. Manual override pin  | 7. Drive sprocket         |
| 3. Power cable          | 8. Mounting Slot          |
| 4. Limit switch housing | 9. Tensioning bolt        |
| 5. Limit switch drive   |                           |



**FIGURE 8. PRODUCT IDENTIFICATION RSO5, RSO5R and RSO5R3P**

- |                         |                           |
|-------------------------|---------------------------|
| 1. Relay/PCB housing    | 7. Manual operation chain |
| 2. Manual override pin  | 8. Ventilation slots      |
| 3. Power cable          | 9. Drive sprocket         |
| 4. Capacitor            | 10. Mounting Slot         |
| 5. Limit switch housing | 11. Tensioning bolt       |
| 6. Limit switch drive   |                           |

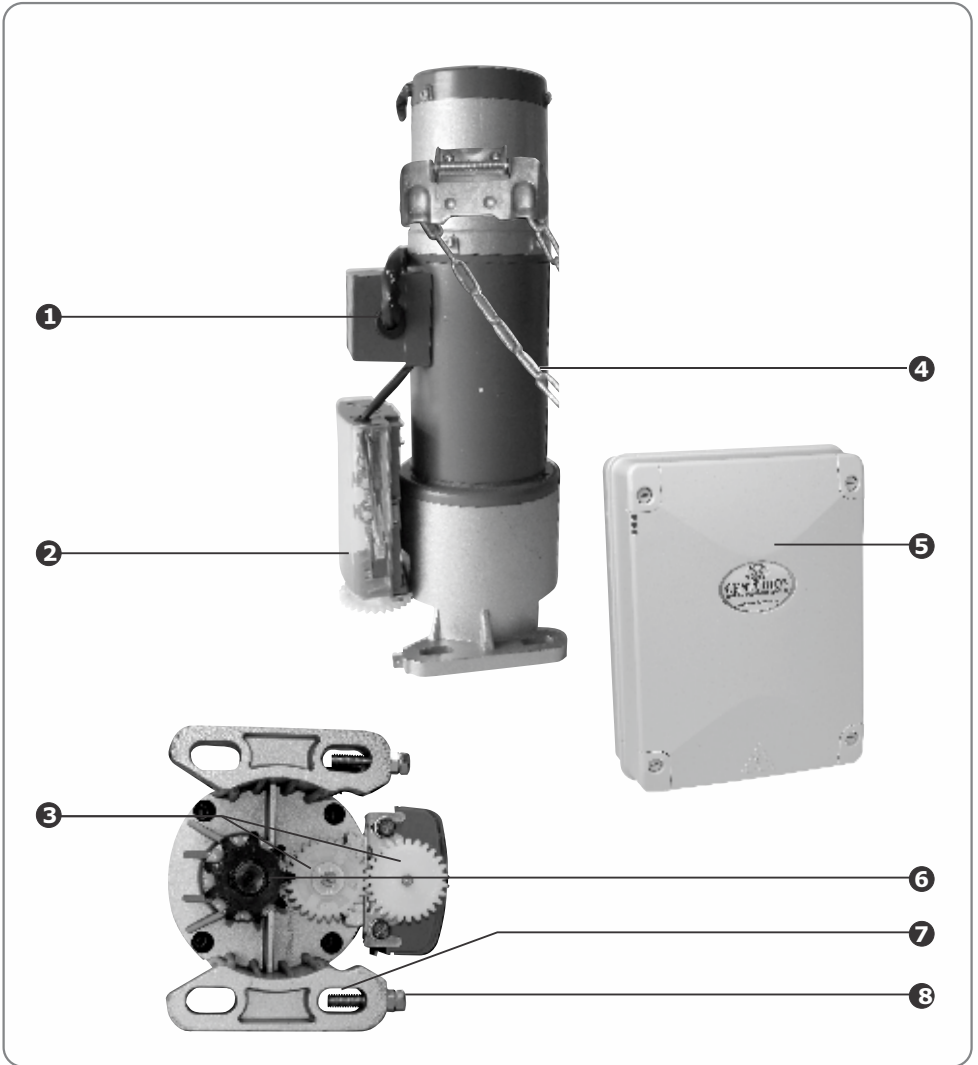

**FIGURE 9. PRODUCT IDENTIFICATION RSO5DC**

- |                             |                    |
|-----------------------------|--------------------|
| 1. Cable junction enclosure | 5. Controller box  |
| 2. Limit switch housing     | 6. Drive sprocket  |
| 3. Limit switch drive       | 7. Mounting slot   |
| 4. Manual operation chain   | 8. Tensioning bolt |

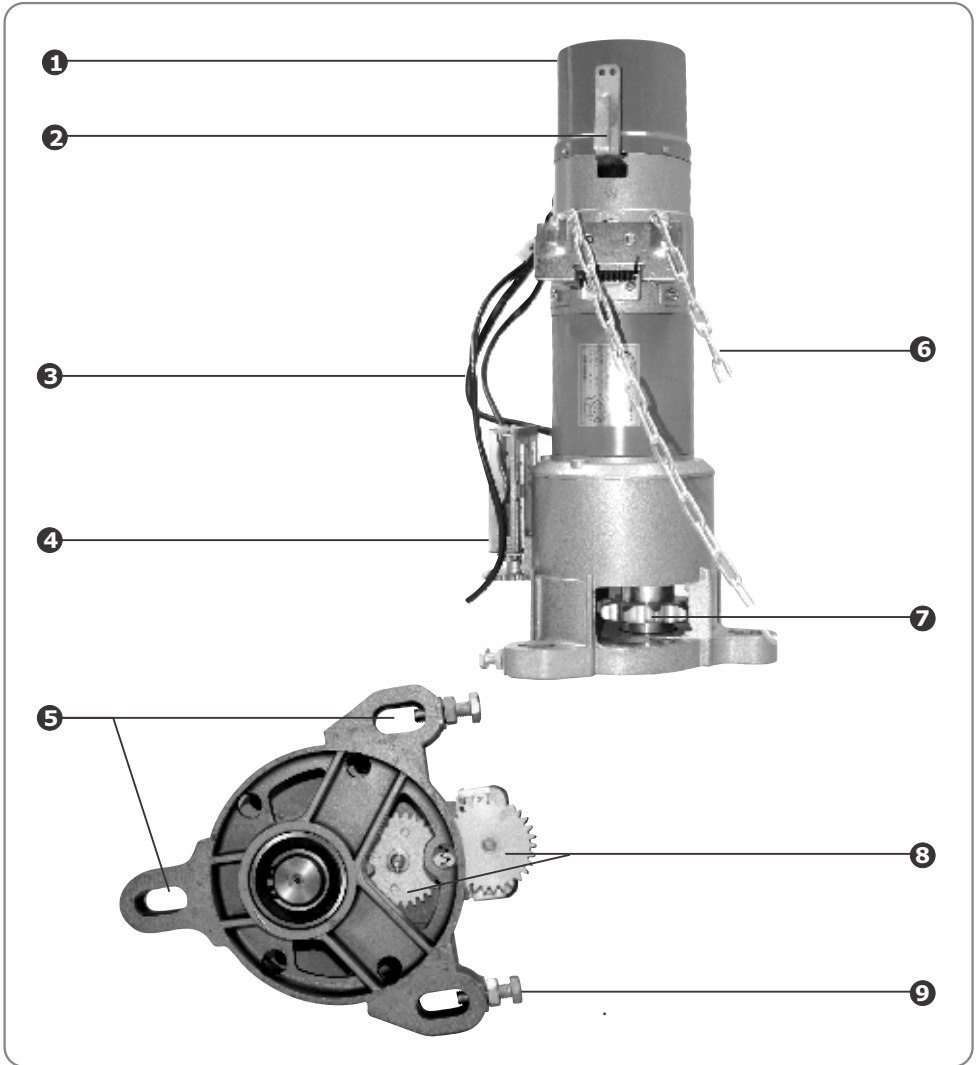

**FIGURE 10. PRODUCT IDENTIFICATION FOR RS09**

- |                         |                       |
|-------------------------|-----------------------|
| 1. Terminal housing     | 6. Hand chain         |
| 2. Manual override pin  | 7. Drive sprocket     |
| 3. Power cable          | 8. Limit switch drive |
| 4. Limit switch housing | 9. Tensioning bolt    |
| 5. Mounting slots       |                       |

## 7. Description of terminal functions

### Opening the enclosure



To access the motor electronics, open the relay/PCB housing by loosening the four screws holding it in place

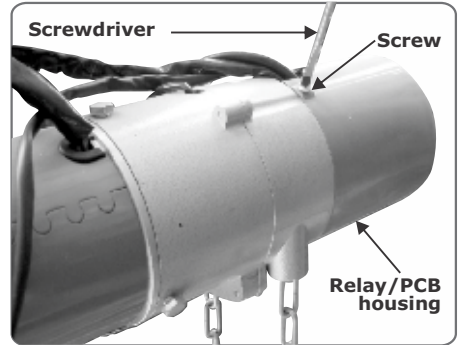

FIGURE 11.

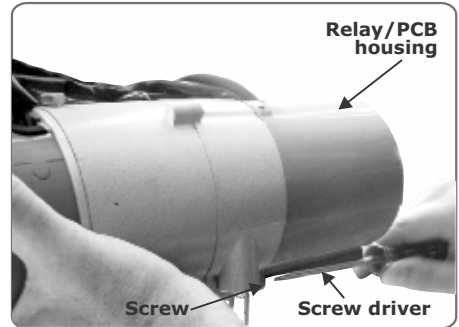
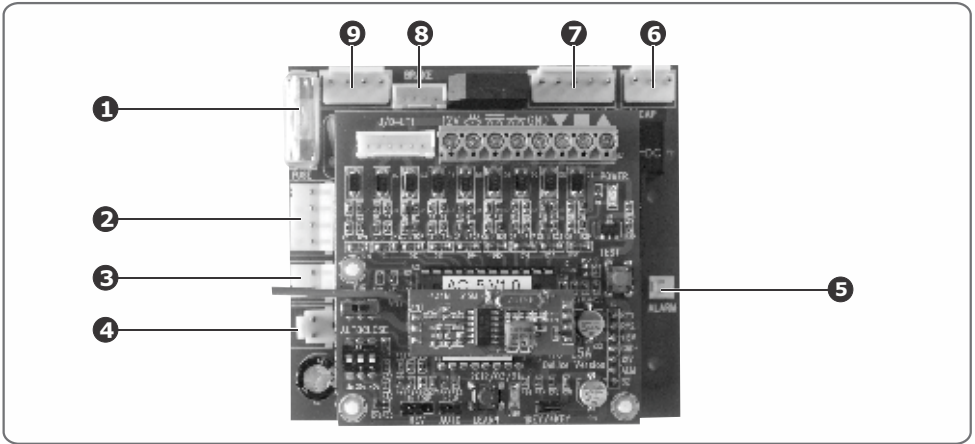

FIGURE 12.

# Motor controller for RSO5 only



**FIGURE 13. AC-L5-B MOTOR CONTROLLER BOARD**

Symbol	Function
1. FUSE	Motor fuse 5A
2. TR1	AC Output
3. TR2	AC 12V input
4. TEMP-FS	Thermal cut-out terminal
5. ALARM	Not used
6. CAP	Capacitor terminal
7. MOTOR	Motor cable terminal
8. BRAKE	Internal disc break terminal
9. POWER	AC power terminal

<b>FUSE</b>	Motor fuse (5A F/B)
<b>TR1</b>	Provides 220V AC to PCB transformer
<b>TR2</b>	12V AC input from the transformer
<b>CAP</b>	Capacitor Terminal. The motor capacitor is connected to this three-pin connector
<b>MOTOR</b>	Motor output. Connects to the motor wires.
<b>BRAKE</b>	This output provides power to the operator’s internal disc break
<b>TEMP-FS</b>	The motor’s temperature cut-out switch is connected to this terminal and will activate in the event of over-temperature
<b>POWER</b>	The 220V -240V AC main power supply is connected to this terminal
<b>ALARM</b>	Not used

# Interface board for RS05 only

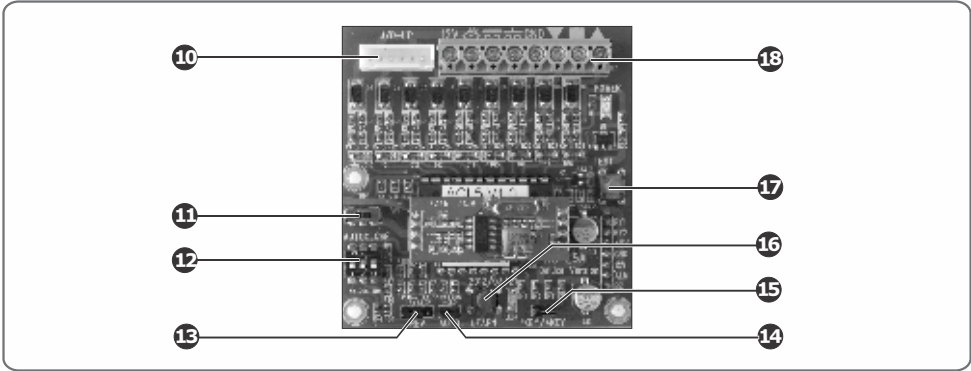





FIGURE 14. AC-L5-A MOTOR CONTROLLER

Symbol	Function
10. LIMIT S/W	Limit Switch terminal
11. DIR	Motor Drive direction switch
12. AUTOCLOSE	Automatic closing time adjustment
13. REV	Infrared Beams Mode selection pins
14. AUTO	Dead man control
15. ONE-KEY/FOUR-KEY	Not used
16. LEARNING PB	Not used
17. TEST	Single button operation
18. G↑STOP↓	I/O terminal

**TEST** Onboard door operation button. This button acts as a trigger. From the fully closed position, pressing the button once will cause the door to start opening, pressing it a second time will stop the door and a third button press will cause the door to start closing

**GND** Ground, common or 12V negative termination point

 Operates in a similar fashion to the onboard test button. A pulse on this input will, from the fully closed position, cause the door to start opening. A second pulse will stop the door and a third pulse will cause the door to reverse direction and start closing

 Safety edge input. If a pressure sensor has been fitted to the shutter's leading edge it must be connected between this input and GND. If an obstruction is encountered, the shutter will behave in exactly the same fashion as when the beam input is activated. (see  on the next page).



This is a normally-open, potential-free contact which will upon closing of the contact (i.e. the beams being broken) cause the curtain to react in one of the following ways: If the REV jumper pins closest to the AUTO jumper have been bridged, the door will stop immediately once the beams have been blocked, regardless of the direction of travel. If the REV pins furthest from the AUTO jumper are bridged and the beam interrupted, the controller will react by emitting a series of beeps and then cause the curtain to re-open for 5 seconds. Should the beam be interrupted again the curtain will stop immediately. If the beams are interrupted while the door is opening the door will stop. If none of the REV pins are bridged and the beam is interrupted while the door is closing, the controller will react by emitting a series of beeps and then cause the curtain to re-open all the way to the open limit. Should the beams stay interrupted the curtain will run in the opening direction for 5 seconds and then stop. If the beams are interrupted again while the door is opening the door will stop.

#### 12V

This terminal provides +12V DC supply for auxiliary equipment such as a radio receiver, photo cells, etc. Maximum 300mA



Closing Input. Momentarily connecting this input to GND will cause the door to travel in the closing direction



Stop Input. Momentarily connecting this input to GND will cause the door to stop moving immediately



Opening Input. Momentarily connecting this input to GND will cause the door to travel in the opening direction

#### DIR

Motor drive direction selection. Confirm the motor direction by using the OPEN, STOP and CLOSE buttons. If the drive direction is incorrect (i.e. the OPEN button closes the door or vice versa), move the switch marked DIR to change the drive direction. Use the controller buttons again to confirm

#### REV ON/OFF

Configures the way in which the curtain will react upon the beam being broken (if beams are connected). If the REV jumper pins closest to the AUTO jumper have been bridged, the door will stop immediately once the beams have been blocked, regardless of the direction of travel. If the REV pins furthest from the AUTO jumper are bridged and the beam interrupted, the controller will react by emitting a series of beeps and then cause the curtain to re-open for 5 seconds. Should the beam be interrupted again the curtain will stop immediately. If the beams are interrupted while the door is opening the door will stop. If none of the REV pins are bridged and the beam is interrupted while the door is closing, the controller will react by emitting a series of beeps and then cause the curtain to re-open all the way to the open limit. Should the beams stay interrupted the curtain will run in the opening direction for 5 seconds and then stop. If the beams are interrupted while the door is opening the door will stop.



**AUTO**

Enabling the Auto functionality allows the user full control over the curtain's closing cycle; in other words, an opening cycle can still be initiated by pressing the Up button only once, but the curtain will only close if the Down button is pressed and held. Releasing the Down button will cause the curtain to stop immediately:

**AUTOCLOSE**

Automatic closing switches. These dipswitches set the time for which the door must remain open before Autoclosing. The Autoclose timer will start counting down upon the door reaching the fully open position. Autoclose time can be set for 5 seconds to 65 seconds, by configuring the dipswitches as follows:

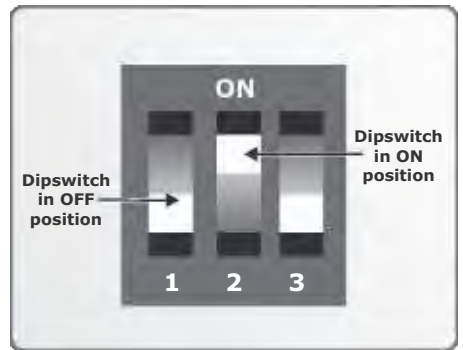

**FIGURE 15. AUTOCLOSE JUMPERS**

Setting	DIP 1	DIP 2	DIP 3
OFF	Off	Off	Off
5 seconds	On	Off	Off
20 seconds	Off	On	Off
25 seconds	On	On	Off
40 seconds	Off	Off	On
45 seconds	On	Off	On
60 seconds	Off	On	On
65 seconds	On	On	On



Infrared safety beams must be installed if Autoclose is to be used

# RSO5DC Controller

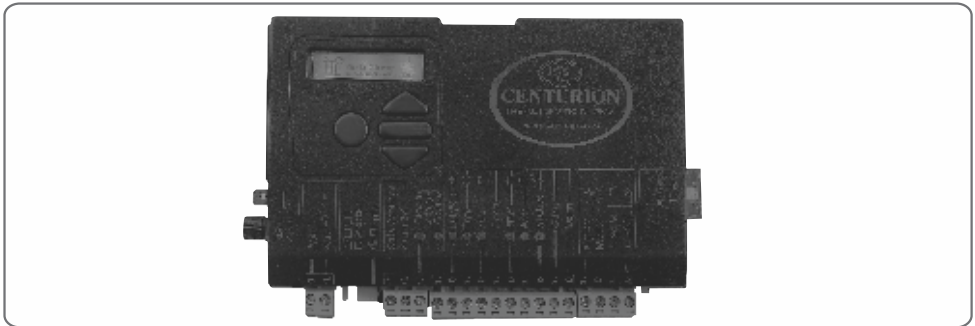



FIGURE 16. RSO5DC CONTROLLER

<b>24V +</b>	<b>Positive battery connection.</b>  (Battery terminal normally indicated as + or RED)
<b>24V -</b>	<b>Negative battery connection.</b>  (Battery terminal normally indicated as - or BLACK)
<b>Motor</b>	<b>Motor output</b> – Connects to the <b>Blue</b> or <b>Black</b> motor wire
<b>Motor</b>	<b>Motor output</b> – Connects to the <b>Orange</b> or <b>Red</b> motor wire
<b>Com</b>	The <b>common</b> termination point. All trigger signals, etc. have their return path to one of the Com terminals.
<b>Status</b>	<b>External shutter status indicator.</b> (A low current output signal.) An output terminal which provides a low current, drive (approx. 4,5V DC, 20mA) to a LED which can be used to indicate the shutter status remotely. If more than three LEDs are required it is necessary to fit the CP78 MULTI LED driver card
<b>Aux</b>	This terminal connects to the RSO5DC's internal solenoid brake. The brake releases whenever the operator receives a trigger signal, and acts as a safety mechanism in the event that the shutter's counterbalance springs fail, engaging and keeping the shutter stationary to prevent it from free-falling
<b>FRX</b>	<b>Free-exit input.</b> (A normally-open potential-free input). Momentarily connecting this input to COM will cause a shutter which is closed, or closing, to open or re-open. If the shutter is open, or opening, the signal has no effect other than to reset the Autoclose timer (if selected). Free-exit (FRX) never initiates a closing cycle. The only way to close a shutter if only the FRX input is used, is to activate the Autoclose feature on the controller.

**Com** The **common** termination point. All trigger signals, etc. have their return path to one of the Com terminals.

**Ped** **Pedestrian opening input.** (A normally-open potential-free input). Momentarily connecting this input to COM will cause the shutter to open to the Pedestrian open position. For more information refer to the Pedestrian feature.

**Trg** **Trigger input.** (A normally-open potential-free input) Momentarily connecting this input to COM will cause the shutter to open or close depending on the operating mode selected. For more information see the Autoclose feature and Modes of Operation.

**Lck/Stp** **Holiday Lockout or gate stop input.** (A normally-closed potential-free input). For as long as a connection between this input and COM is maintained the controller will behave normally. But, when this connection to COM is broken all inputs are inhibited, and if the shutter is moving it will stop.



If the Lck function is not required a link must be fitted between Lck and Com

**Safety Open Opening beam safety input.** (A normally-closed potential-free input). As long as a connection between this input and Safe Common is maintained the controller will behave normally. When this connection is broken it will prevent the gate from opening if it is stationary, and will stop and close the gate if it is opening. This input has no effect if the gate is closing.



When setting up the controller for the first time or after a full reset back to factory defaults has been performed, the system will electronically override the Safety Inputs and allow the system to function without the links. However if safeties are connected to either or both inputs, thereafter there must be a normally-closed circuit maintained for the system to operate correctly. I.e. if beams are fitted and then removed, the circuit which is affected must be replaced with a wire link to create the normally-closed circuit.

**Safety Close Closing edge safety input.** CLOSING edge safety input. (A normally-closed potential-free input). For as long as a connection between this input and COM is maintained the controller will behave normally. When this connection is broken it will prevent the shutter from closing if it is stationary, and will stop and reverse the shutter if it is closing. This input has no effect if the shutter is opening



If the Saf CLO function is not required a link must be fitted between Safe CLO and COM for the controller to operate normally.)

**Aux 12V Out Auxiliary power connection.** Auxiliary power connection. Provides a +12V DC supply for auxiliary equipment such as a radio receiver, photo cells etc, It is linked directly to the battery positive via a 3A resettable fuse.

**Safe Com** Used for switching the power supply to the safety beams. If automatic beam testing is required, the negative power supply connection of the beam transmitters and receivers must be wired to this point.

**LIT** Pillar light connection. These two terminals provide a normally-open, potential-free contact which is generally used to switch on a pillar light (courtesy light). This contact is fuse protected – refer to pg48 for fuse specifications

## 8. Required tools and equipment

- Welding equipment
- Spanner 17mm; 13mm
- Spirit level
- Circlip pliers
- Allen key set
- Long-nosed pliers
- Angle grinder and cutting discs
- Electric drilling equipment
- Masonry bits for mounting wall pendant
- Steel bits
- Phillips screwdriver
- Marking pen/chalk
- Extension cord
- G-Clamps
- Depending on the height at which the **RSO** is to be installed, scaffolding and safety harnesses may be needed
- Gear puller for removing old sprocket

## 9. Preparation of site

### General considerations for the installation

- Gather all necessary tools and assemble any scaffolding and safety equipment that may be required to safely gain access to the area where the **RSO** is to be installed
- Ensure that the door is properly balanced by manually opening it halfway. It should ideally remain in this position and should not move of its own volition for more than about 100mm of travel in either direction
- Fully open the door to be automated and ensure that it is securely locked in place. This is imperative since the door could free-fall which could lead to personal injury or even death

### Minimum clearance

Operator	Minimum A dimensions
RSO5R	590mm
RSO5R3P	590mm
RSO5	620mm
RSO5DC	460mm
RSO9	650mm

The A dimension refers to the minimum amount of space needed to install each operator, i.e. the distance from the side of the shutter box to the first obstruction (eg. a pillar)

If these minimum clearance requirements are not met, i.e. there is limited space available for mounting the operator facing outwards, it is possible to reverse the mounting plate so that the operator faces the opposite direction as shown in Figure 17.'

We then need to insert an image, similar to the one above, with the unit facing the other direction.

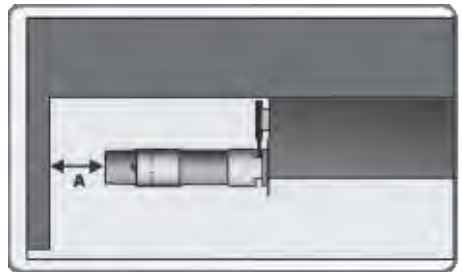

FIGURE 17.

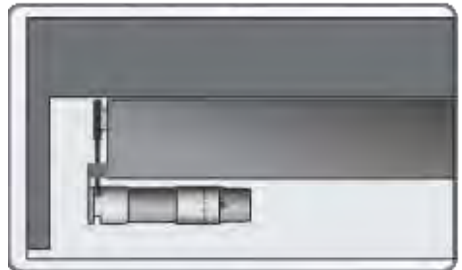

FIGURE 18.

## 10. Cabling requirements

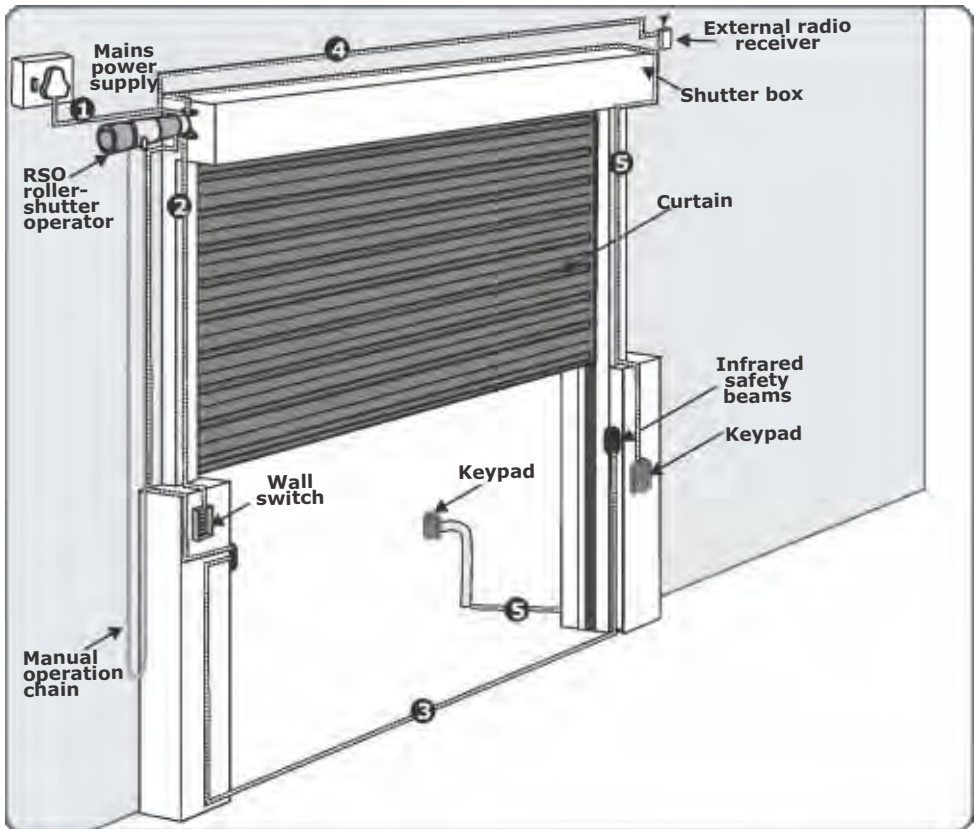
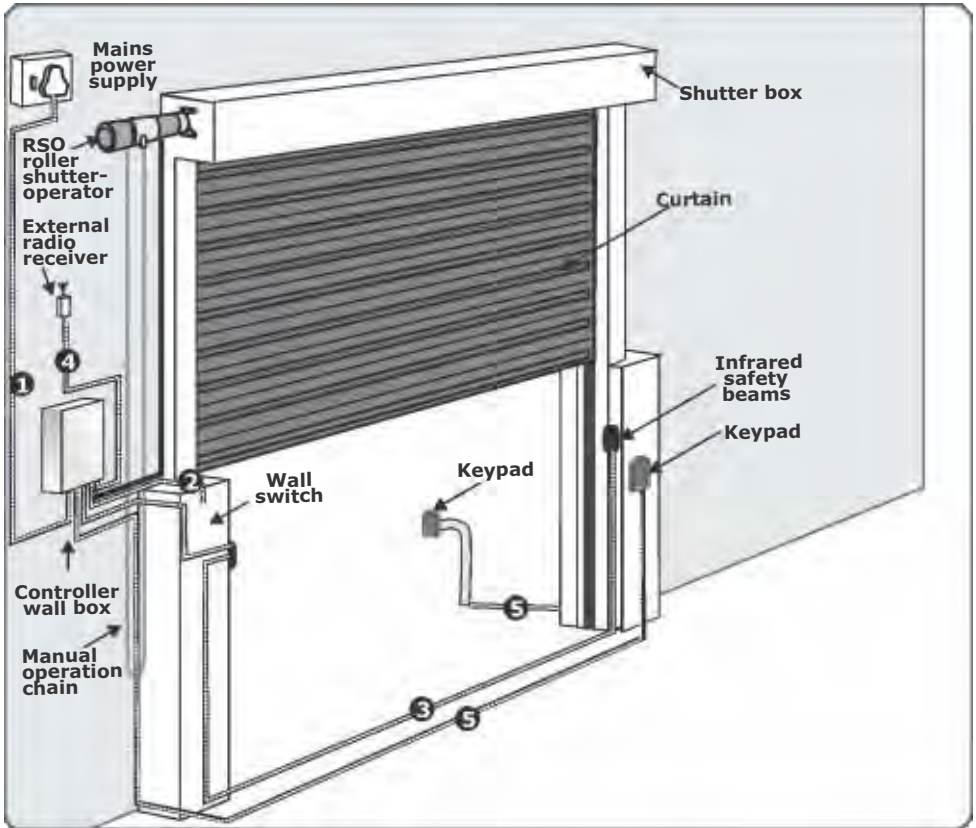

FIGURE 19. CABLING REQUIREMENTS

1. 220V - 240V<sup>®</sup> AC mains cable (3 core LNE 1.5mm<sup>2</sup> SWA).
2. Cable for wall switch (supplied).
3. Optional but recommended infrared safety beams (3 core 0.5mm<sup>2</sup> multi-stranded).
4. Radio receiver cable (3 core 0.5mm<sup>2</sup> multi-stranded).
5. Optional keypad (3 core 0.5mm<sup>2</sup> multi-stranded).

\* 380V AC 3Ø for three phase models

# RS05DC cabling requirements



**FIGURE 20. CABLING REQUIREMENTS FOR RS05DC**

1. 220V - 240V<sup>⊖</sup>AC mains cable (3 core LNE 1.5mm<sup>2</sup> SWA).
2. Cable for wall switch (supplied).
3. Optional but recommended infrared safety beams (3 core 0.5mm<sup>2</sup> multi-stranded).
4. Radio receiver cable (3 core 0.5mm<sup>2</sup> multi-stranded).
5. Optional keypad (3 core 0.5mm<sup>2</sup> multi-stranded).

\* 380V AC 3Ø for three phase models



# 11. Installation procedure

## Retrofit installations

The following installation procedure applies to roller-shutter doors that have already been installed, and must now be automated:

1. Using a G-clamp, secure the curtain in the fully OPEN position.



It is recommended that the installation is performed while the curtain is open, as the helical coil springs are under the least amount of tension in this position. Working on a roller-shutter while the springs are fully tensioned holds significant safety risks as the shutter could come loose with great force at any moment, resulting in personal injury or even death

2. Remove the chain wheel by loosening the bolt holding it in place; this is commonly a M8 bolt but can be any size.
3. After removing the chain wheel, unhook the manual operation chain from the drive
4. Remove the old sprocket. The sprocket is commonly held in place by a circlip but, as the sprocket often sits quite tightly on the shaft, it is at times necessary to make use of a gear puller in order to remove it.

5. In order to provide adequate space for the **RSO** to be installed, some or all of the old fittings or support struts may have to be grinded off. Ensure that the surface is completely smooth and that there are no uneven areas or protrusions where the motor is to be installed as shown in Figure 21.

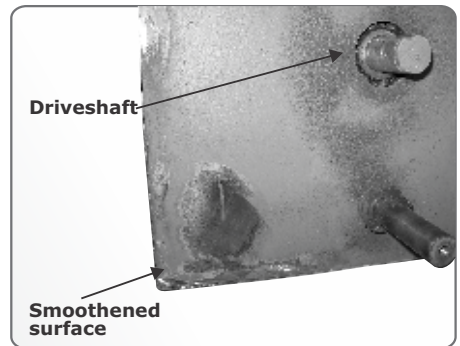

FIGURE 21.

6. Weld the brace bracket onto the side of the shutter box as shown in Figure 22

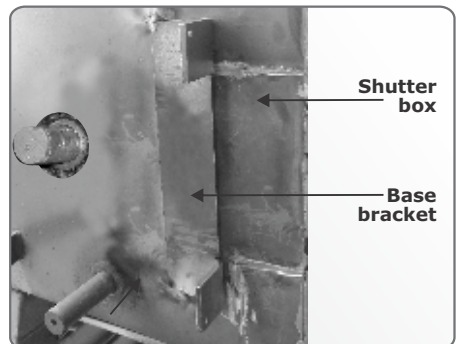

FIGURE 22.

7. Tack-weld the flanges of the mounting plate onto those of the brace bracket as shown in Figure 23, giving special consideration to available space and the direction that the operator will face.

The mounting plate can be adjusted left and right, parallel to the shutter box along the mounting flanges to ensure that the plate wheel and the operator's sprocket are properly aligned.



If there is not enough space to mount the operator facing outwards, the mounting plate can be reversed so that the operator faces the opposite direction. This method is shown in Figure 18.

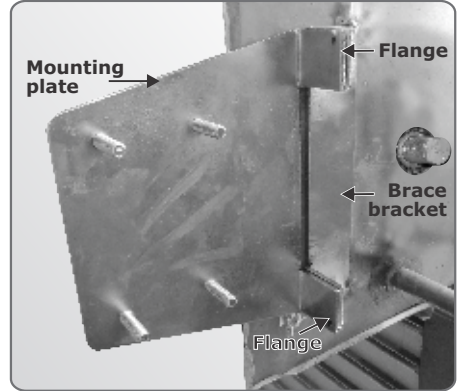

FIGURE 23

8. Insert the taper bush into the plate wheel as shown in Figure 20 and use the two grub screws to secure the bush in place.



If at any stage the taper bush must be removed, remove both of the grub screws and insert one of them into the previously unused slot, and tighten

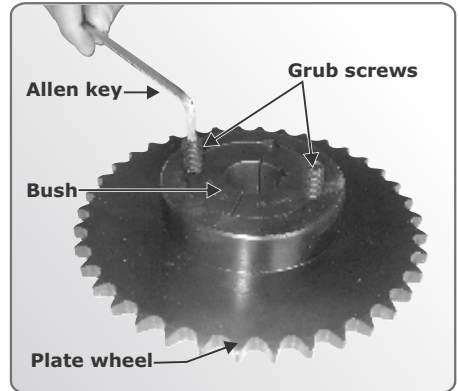

FIGURE 24

9. Fit the sprocket supplied with the **RSO** kit onto the door's driveshaft and insert the square key(not supplied) into the slot as shown in Figure 25.



Ensure that you purchase the correct taper bush size. Both 30mm and 35mm taper bushes are available

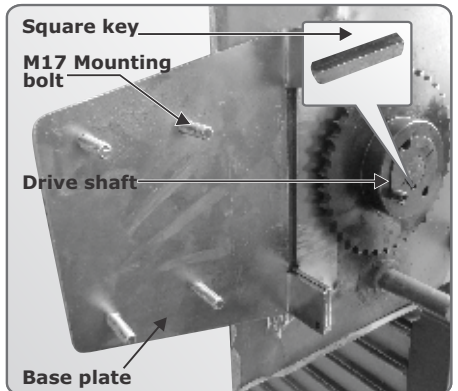

FIGURE 25

9. Always ensure that the hand chain hangs vertically. If the operator cannot be mounted in a way that facilitates this, the chain housing can be swivelled by loosening the three M8 bolts as shown in Figure 22.

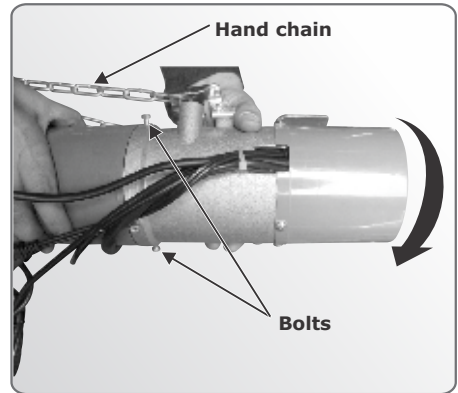

FIGURE 26

10. The motor can now be fitted onto the four mounting bolts. Do not tighten the nuts yet, as the motor must still be positioned in such a way that it tensions the drive chain. Ensure that the motor's output pinion is directly in line with the sprocket as misalignment may result in the chain being pulled from the sprocket once the door is set in motion. Additional washers may be fitted onto the mounting bolts and the motor slightly raised from the plate in order to align the pinion with the sprocket.

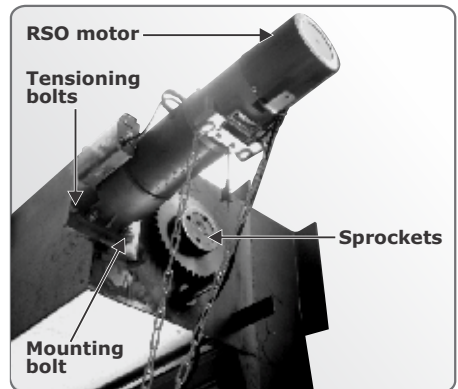

FIGURE 27



Remove the safety clip from the drive chain and break the chain as shown in Figure 24, before connecting it to the pinion

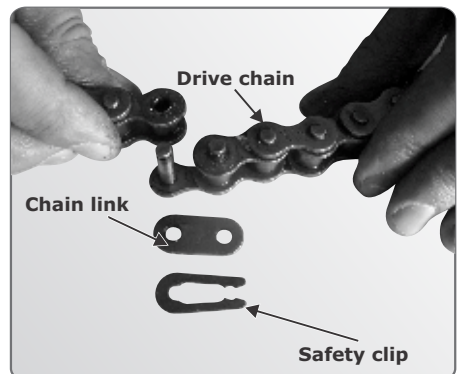
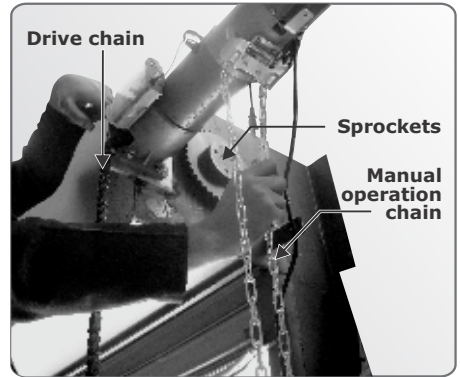

FIGURE 28

11. Connect one end of the drive chain to the pinion and use the manual operation chain to feed it.
12. Use a pair of long-nosed pliers to join the two ends of the chain, remembering to fit the safety clip.



**FIGURE 29**

## 12. Electrical setup

### Secure wall pendant

Mount the Three-Button Wall Switch in such a way and at such a height that it can be comfortably operated. An optional, lockable enclosure can be purchased from Centurion Systems for added security and to prevent unauthorised and unsafe use of the operator.

- Separate the two halves of the Wall Switch Enclosure by loosening the two fixing screws on the face
- Secure the posterior (back) half to the wall using the most appropriate means, be it rawbolts, sleeve anchors, etc.
- Fit the anterior (front) of the enclosure assembly to the back plate and secure using the two fixing screws provided

### Connect all wiring

Connect all cables as required according to the wiring diagram shown in Figure 25

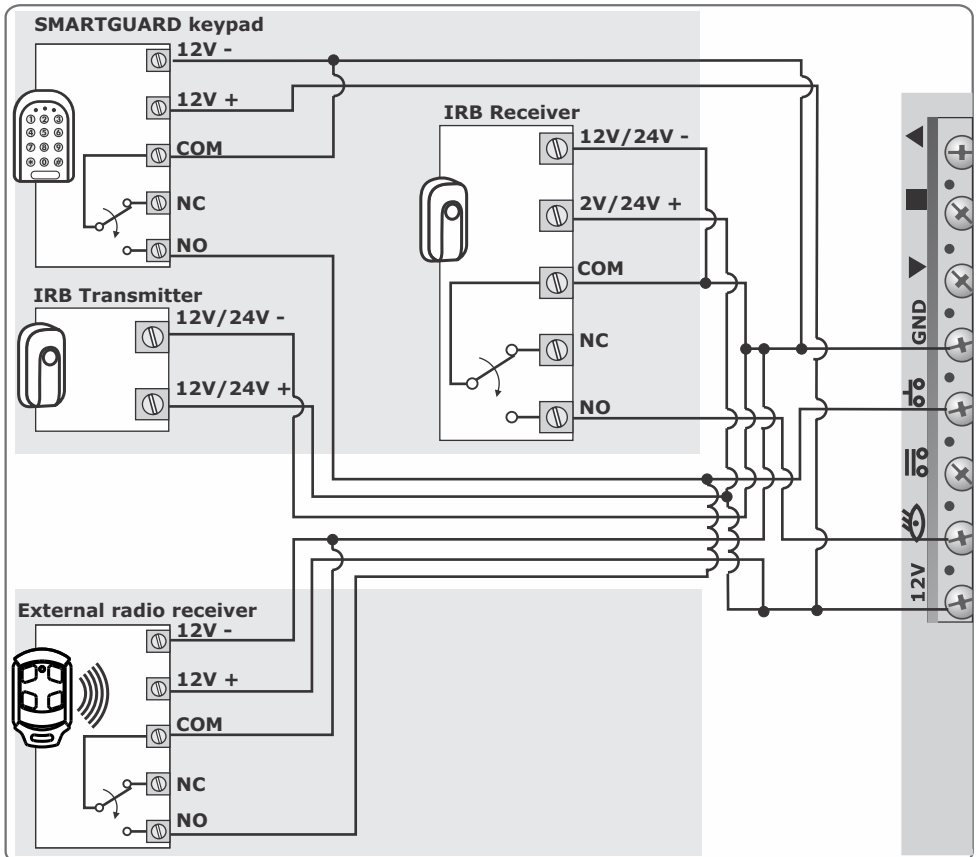

FIGURE 30. RSO5 WIRING DIAGRAM

## RSO5DC connections and wiring

1. Secure the control box to the wall using the most appropriate means.  
Be sure to position the wall box so as not to cause any hazards during and after the installation:  
Preferably mount the wall box:
  - Out of direct sunlight
  - At a comfortable working height
2. Crimp the supplied bullet lugs onto the 0.5mm<sup>2</sup> white, yellow and green wires.
3. Route the three wires through one of the compression glands supplied and then through the knock-out at the bottom of the wall box.
4. Connect the wires from the operator to the wires from the controller in the following configuration:
  - Green – green
  - Yellow – yellow
  - White – white

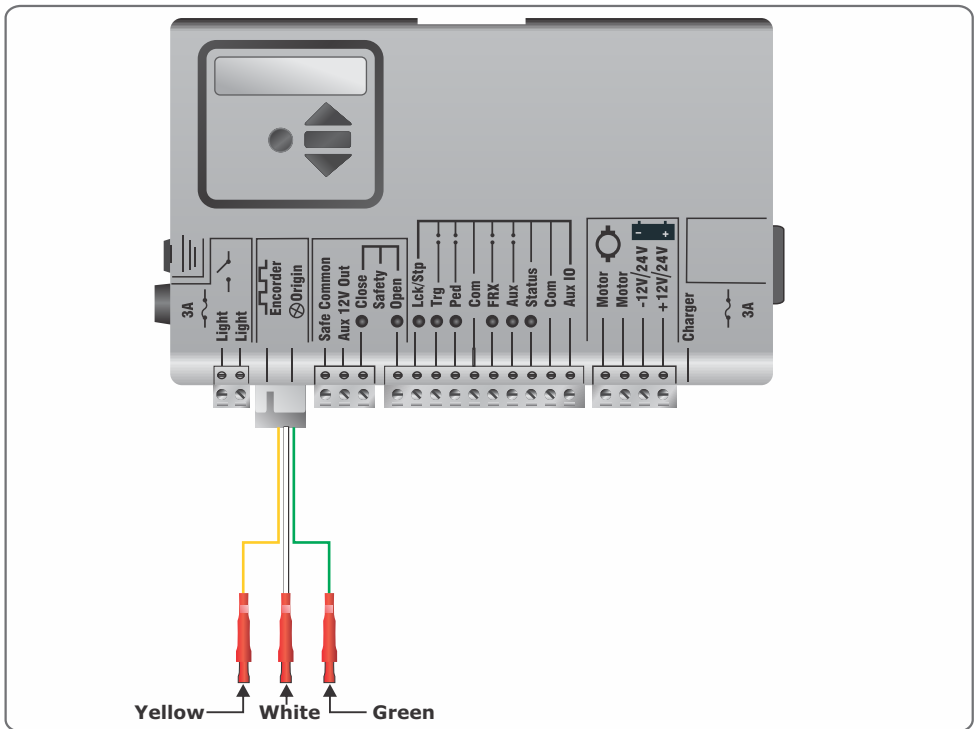

FIGURE 31

4. Connect the two black motor wires to either one of the Motor terminals on the controller (the Motor terminals are not polarity-sensitive).
5. Connect the two red motor wires to the remaining Motor terminal.

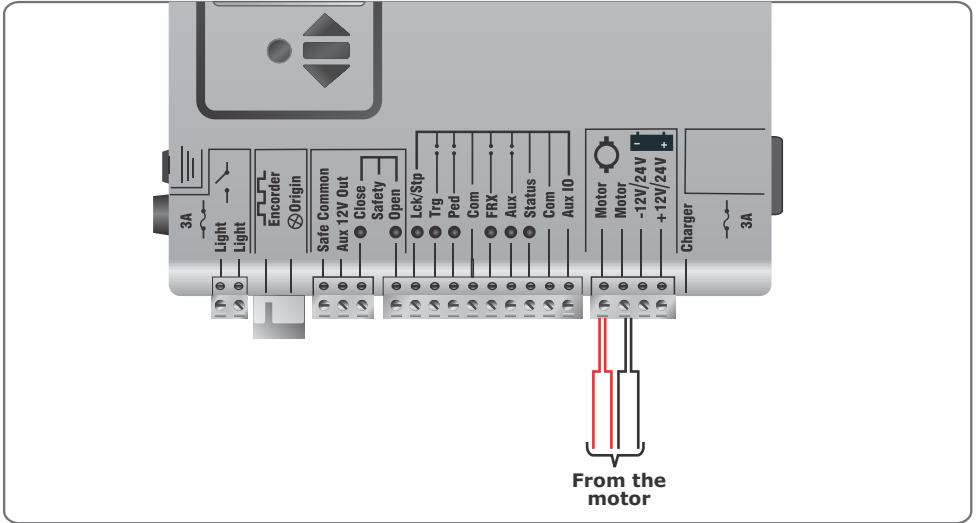

FIGURE 32

6. Now connect either of the two 0.2mm<sup>2</sup> white wires to the relay card's normally-open (N/O) terminal. The relay card is also housed within the wall box enclosure.

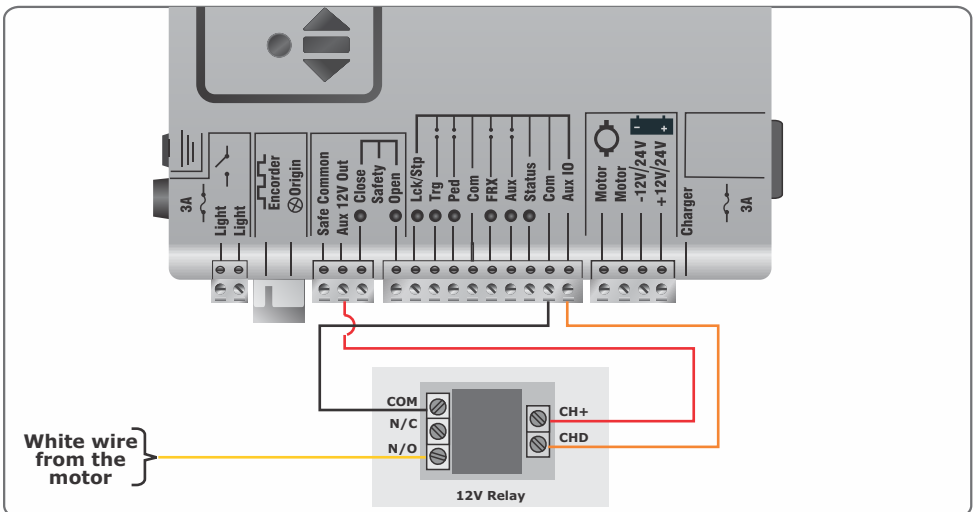

FIGURE 33.

7. Connect the other white wire by crimping it into the female blade connector (supplied) and then connecting it to the positive (+) battery terminal via the male 3-way blade expander as shown in Figure 29

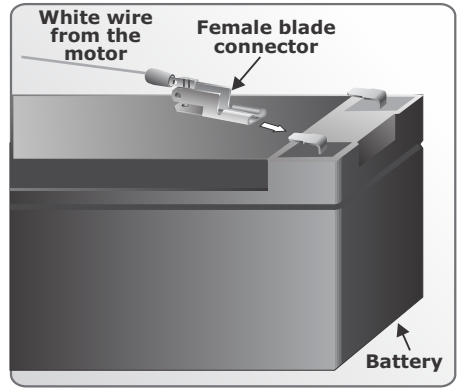

FIGURE 34.

8. Heeding the necessary safety precautions, connect the 220 – 240V AC mains supply to the wall box isolator. To access the wiring terminals of the isolator, unscrew the two Philips screws and connect the Live and Neutral wires.

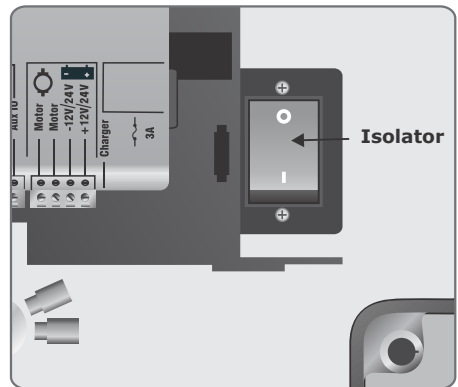

FIGURE 35

9. Fasten the 220V earth cable onto the earth stud in the wall box enclosure as shown in Figure 31

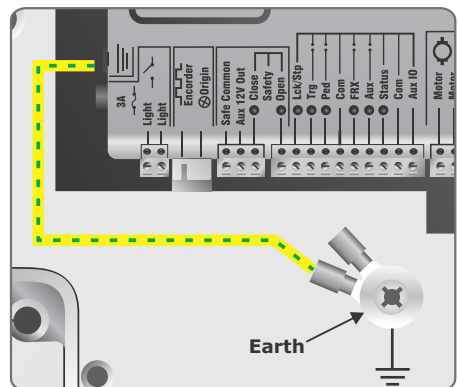

FIGURE 36



10. Connect the two batteries to the controller as shown in Figure 32.

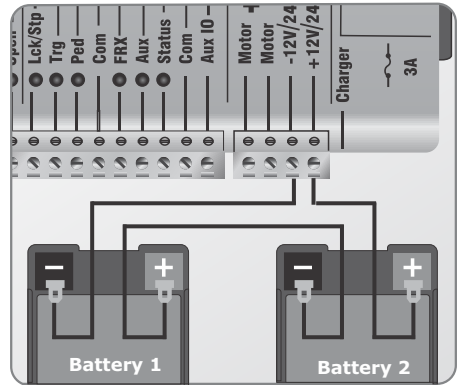

FIGURE 37

## RSO5DC menu navigation map



### 1. Setting limits



#### 1.1. Setup wizard



### 2. Safety

- 2.1. Collision force ..... 2.1.1. Opening collision force
  - 2.1.2. Closing collision force
- 2.2. Collision count
- 2.3. Alarm output
- 2.4. LCK as ESTOP
- 2.5. External gate status indication..... 2.5.1. Indicator output
  - 2.5.2. Closed indication
  - 2.5.3. Part close indication
  - 2.5.4. Closing indication
  - 2.5.5. Part open indication
  - 2.5.6. Opening indication
  - 2.5.7. Open indication
  - 2.5.8. Pedestrian indication
  - 2.5.9. Unknown indication



### 3. Autoclose

- 3.1. Autoclose status
- 3.2. Autoclose timer
- 3.3. Autoclose override
- 3.4. Autoclose advanced options ..... 3.4.1. Autoclose fully open
  - 3.4.2. Autoclose partly open
  - 3.4.3. Autoclose partly closed



#### 4. Modes of Operation

- 4.1. Operating mode.....
  - 4.1.1. Standard Mode
  - 4.1.2. Condominium Mode
  - 4.1.3. Reversing Mode
  - 4.1.4. PLC
  - 4.1.5. Deadman Control Mode



#### 5. Run profile

- 5.1. Positive close .....
  - 5.1.1. Positive Close Mode status
  - 5.1.2. Positive Close Mode force
- 5.2. Pre-open delay
- 5.3. Pre-close delay
- 5.4. Opening speed
- 5.5. Closing speed



- 5.6. Ramp-up distance
- 5.7. Ramp-down distance
- 5.8. TRG stop distance
- 5.9. IRB stop distance
- 5.10. Crawl distance
- 5.11. Torque limit
- 5.12. PWM minimum



#### 6. Infrared beams

- 6.1. PIRAC control.....
  - 6.1.1. PIRAC status
  - 6.1.2. Stop on open.....
    - 6.1.2.1. Stop on open status
- 6.2. IR beam test.....
  - 6.2.1. Status
  - 6.2.2. Test beam
- 6.3. IRBO=IRBC on closing
- 6.4. IR beam alarms.....
  - 6.4.1. Ambush alarm.....
    - 6.4.1.1. Ambush alarm status
  - 6.4.2. Break-in alarm.....
    - 6.4.1.2. Broken IRB time status
  - 6.4.3. Alarm output



#### 7. Pedestrian

- 7.1. Pedestrian open position
- 7.2. Pedestrian Autoclose time
- 7.3. Pedestrian pre-open delay
- 7.4. Pedestrian pre-close delay



## 8. Courtesy light

- 8.1. Courtesy light timer
- 8.2. Light profile.....
  - 8.2.1. Courtesy light
  - 8.2.2. Pre-flash A
  - 8.2.3. Pre-flash B
  - 8.2.4. Pre-flash C



## 9. ChronoGuard

- 9.1. Time and date
- 9.2. Time periods.....
  - 9.2.1. Add time period.....
    - 9.2.1.1. Auto function
    - 9.2.1.2. Time-bar. function
  - 9.2.2. Delete time period
  - 9.2.3. Edit/review time periods



- 9.3. Exclusions .....
  - 9.3.1. Add exclusion .....
    - 9.3.1.1. Auto function
    - 9.3.1.2. Time-bar function
  - 9.3.2. Delete exclusion
  - 9.3.3. Edit/review exclusions
- 9.4. Delete all time periods and exclusions



## 10. General settings

- 10.1. Operating standard
- 10.2. Reset options .....
  - 10.2.1. Factory defaults
  - 10.2.2. Delete all remotes
  - 10.2.3. Delete all time periods and exclusions
  - 10.2.4. Reset all
- 10.3. Diagnostic screen status
- 10.4. Test button disabled status
- 10.5. Backup EEPROM
- 10.6. Restore EEPROM



## 11. Remote controls



Press button of valid transmitter *(if menu locked)*

- 11.1. Add remotes
- 11.2. Delete remotes .....
  - 11.2.1. Delete remote by ID
  - 11.2.2. Delete remote button
  - 11.2.3. Delete remote by button
  - 11.2.4. Delete not present
  - 11.2.5. Delete all remotes
- 11.3. Edit remote button
- 11.4. Autolearn
- 11.5. Lock Tx menu
- 11.6. Onboard receiver enable/disable

## RSO5DC Controller features



### Menu 2 - Safety (collision force)

#### • Collision force

If the shutter is obstructed, the internal collision circuitry will activate. The response of the system to a collision will vary, depending on the profile (operating standard, e.g. ZA,) selected. Responses can vary from the shutter stopping, to the shutter reversing. The collision force can be set from minimum to maximum in five discrete steps

A sixth step will disable collision sensing entirely, allowing maximum force to be achieved. Under this condition, the motor will continue running until it stalls, at which point a collision will be detected



This level should only be used if additional safety measures are taken. (E.g.: Infrared beams, sensitive edge etc.) Collision force can be set independently per direction of travel.

#### • Collision count

- A counter monitors the number of collisions that the shutter experiences before it reaches the fully closed position. If the value exceeds the value set in the **multiple collision counter** the controller shuts down until the next valid trigger is received. As indication, the **status** LED will flash four times every two seconds. The **multiple collision** fault indication will continue to flash indefinitely or until a valid trigger has been received

#### • Alarm output

After the preset collision count has been reached, an alarm is activated. The system can be configured to operate one of the following outputs provided on the controller:

- **Pillar / Courtesy light contact** (potential-free normally-open contact, fuse protected – 5A)
- **Safety beam common** (this is an open collector drive, max current draw 3A, not fuse protected)
- **Status LED output** (operate up to three LEDs in parallel or interface with multi-LED driver card, CP78)
- **LCK as ESTOP**  
Allows the LCK (Holiday Lockout) input to be configured as an emergency stop input



## Menu 3 - Autoclose

- **Autoclose status**
  - The **Autoclose** feature when turned on, has the function of automatically closing the shutter after a preset **Autoclose** time. The **Autoclose** feature is automatically turned on when the controller is set for **Condominium** Mode of Operation.
- **Autoclose time**
  - The **Autoclose** time can be set anywhere from 1 to 255 seconds.
- **Autoclose override**
  - It is possible for the user to temporarily turn off Autoclose when the Mode of Operation is **Standard** or **Reversing**. To activate **Autoclose override**, the **TRG** input must be activated and maintained for a period longer than the time set for the **Autoclose Override Time**, after which the input can be cleared; ie press and hold the button of the remote that operates the roller-shutter
  - The shutter response will be to start opening on the first **TRG** trigger, and then to stop as soon as the **Autoclose Override** feature is activated. On clearing of the **TRG** input, the shutter will continue opening until fully open. The **Autoclose** feature is now off and the shutter will remain open indefinitely
  - The next signal received on **TRG** will clear the **Autoclose Override** feature, close the shutter, and set the **Autoclose** feature back to normal
- **Autoclose advanced options**
  - The conditions under which the shutter will Autoclose can be set within the **Advanced Autoclose** options menu:
    - **Autoclose on open** - automatically close the shutter if it has reached the fully open position
    - **Autoclose on partly open** - automatically close the shutter if it is stopped while opening, but before reaching the fully opened position
    - **Autoclose on partly closed** - automatically close the shutter if it is stopped while closing, but before reaching the fully closed position



More than one advanced option can be selected



## Menu 4 - Modes of Operation

It is possible to select the following Modes of Operation: **Standard**, **Condominium**, **Reversing**, **PLC** and **Deadman control Mode**. All modes are triggered by closing a normally-open contact between the **TRG** input terminal and the **COM** terminal

- **Standard mode**

When stationary, a trigger impulse on **TRG** will cause the shutter to either open or close. On a moving gate, a trigger impulse on **TRG** will stop the shutter. A third impulse on **TRG** will cause the shutter to reverse its direction of travel, i.e. the action is **Start - Stop - Reverse**

- **Condominium mode**

A trigger impulse on **TRG** will under all conditions open the shutter. If it were closing, it will stop and reverse to open. In this Mode of Operation, the only way to close the shutter is with the **Autoclose** feature which is automatically activated when **Condominium** mode is selected

- **Reversing mode**

A trigger impulse on **TRG** will reverse the direction of a moving shutter. If it were closing, it will stop and immediately begin opening. If it were opening, it will stop and immediately begin closing.

- **PLC Mode**

- A trigger impulse on **FRX** (N/O) will cause the shutter to open. A trigger impulse on the **TRG** (N/O) will cause the shutter to close
- A trigger impulse on the **LCK/STP** (N/C) will cause the shutter to stop

- **Deadman Control Mode (DMC)**

- A permanent trigger on **FRX** (N/O) will cause the shutter to open. Removing the trigger will cause the shutter to stop
- A permanent trigger on **TRG** (N/O) will cause the shutter to close Removing the trigger will cause the shutter to stop
- A permanent trigger on **LCK/STP** (N/C) will stop a moving shutter, and



## Menu 5 - Run profile

- **Positive Close Mode (PCM)** (not recommended for roller-shutters)

Setting **Positive Close Mode** to ON will allow the curtain to drive up hard to an endstop without causing the collision circuitry to operate. This feature operates only during the last few millimeters of shutter travel in closing mode

- **PCM push force**

The amount of force applied by the motor when in PCM can be set as a percentage of full motor force

- **Pre-open delay**

Allows a delay between a valid trigger signal being received and the shutter commencing movement in the opening direction. A warning light can be set to activate during this delay. (Refer to Pre-flash modes of the feature PILLAR LIGHT, for more details)

- **Pre-close delay**

Allows a delay between a valid trigger signal being received and the shutter commencing movement in the closing direction. The delay will also occur if the shutter is set to close automatically. A warning light can be set to activate during this delay. (Refer to Pre-flash modes of the feature PILLAR LIGHT, for more details)

- **Opening speed**

Sets the opening speed as a percentage of the maximum shutter speed. This can be set from 22-100%. Selecting max will move the shutter at maximum possible speed

- **Closing speed**

Sets the closing speed as a percentage of the maximum shutter speed. This can be set from 22-100%. Selecting max will move the shutter at maximum possible speed

- **Ramp-up distance**

Sets the ramp-up distance as a percentage of travel of the shutter when an endpoint is reached. This can be set from 2% to 30% in 1% steps

- **Ramp-down distance**

Sets the ramp-down distance as a percentage of travel of the shutter when stopping. This can be set from 2% to 30% in 1% steps.

- **TRG stop distance**

Sets the distance over which a moving shutter will stop after a TRG input is received, as a percentage of total shutter travel. This can be set from 1% to 10% in steps of 1%

- **IRB Stop Distance**

Sets the distance over which a moving gate will stop after an Infrared Safety Beam is broken, as a percentage of total shutter travel. This can be set from 1% to 10% in steps of 1%

- **Crawl Distance**

Sets the final crawl distance as a percentage of travel of the shutter when reaching an endpoint. This can be set from 5% to 30% in steps of 1%

- **Torque Limit**

Sets the maximum torque delivered by the motor. The maximum setting is a value of 10 and the minimum is 4. This is useful in cases where limited push force is required

- **PWM Minimum**

Sets the minimum speed at which the shutter will be allowed to crawl, both during the limit setup procedure and during normal operation before reaching an endpoint. The maximum setting is a value of 90% of maximum speed and the minimum is 5%. It is highly recommended that the PWM Minimum be set to maximum during limit setup, as configuring it to a lower value will result in the procedure taking unnecessarily long



## Menu 6 - IR beams

- **PIRAC**

Passive-Infrared Autoclose causes the shutter to automatically close as soon as a vehicle has passed through the closing beams. This security feature ensures that the shutter stays open for the minimum amount of time possible

If the AUTOCLOSE feature has been enabled when the shutter is triggered to open, but nothing moves through / breaks the closing beam, the shutter will open fully and stay open for the period of time determined by the AUTOCLOSE timer. However, if at any stage, while the shutter is opening or standing open waiting to close, the beams are broken, the shutter will close immediately

- **IR Beam Test**



Automatically tests the safety beams before each shutter cycle. (eg as required by CE and UL325).

In order for this feature to work, the power supply negative of the beam transmitter must be wired to the SAF COM terminal of the controller

- **IRBO=IRBC**

Configures the opening beam to act as a closing beam while the shutter is closing



- **IR beam alarms**

While the gate is fully closed, this feature allows the following alarms:

- **Ambush alarm**

Activates an alarm if either the opening or closing beams have been continuously interrupted for a predefined time. The alarm will remain activated while the beams are interrupted.

For example, if a would-be intruder covers the beams so that when the gate is opened, the gate will stay open, the system will detect this beam override taking place and set off an alarm.

- **IR beam broken time**

The time that the beams must be interrupted before the alarm is activated.

- **Break-in alarm**

Activates an alarm if the closing beam on the outside of the property is interrupted. The alarm remains activated while the beams are broken, and for a period of 30 seconds thereafter. This time is fixed.



If this alarm is used, it is recommended that TWO parallel closing beams are used to reduce the chance of false triggering.

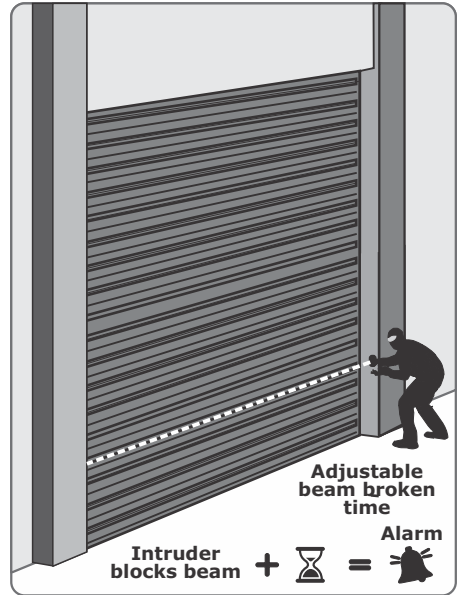

FIGURE 38



FIGURE 39

- **Alarm output**

The system can be configured to operate one of the following outputs provided on the controller:

- **Onboard buzzer** – emits a continuous tone.
- **Pillar / Courtesy light contact** (potential-free normally-open contact, fuse protected – 3A).
- **Safety beam common** (this is an open collector drive, max current draw 3A, not fuse protected).
- **Status LED output** (operate up to three LEDs in parallel or interface with multi LED driver card, CP78).



## Menu 7 - Pedestrian opening

This feature is associated with the PED input on the controller. When activating this input, the system will open the shutter to the pedestrian open position, and then automatically close after the pedestrian Autoclose time lapses. The shutter will open only after the adjustable pre-opening delay time.

If the connection to COM is maintained then the shutter will remain open, and when the connection is broken, it will close after the PEDESTRIAN Autoclose time.

- **Pedestrian open position**

Sets the maximum distance that the shutter will open for pedestrians as a percentage of the total shutter travel..

- **Pedestrian Autoclose time**

Sets the Autoclose time in seconds after a pedestrian opening.

- **Pedestrian pre-open delay**

Sets the time delay between the pedestrian input being activated, and the shutter actually opening. While this feature can be used with roller-shutters, it is mostly a safety feature associated with sliding and swing gate motors where pedestrians have to reach through the gate in order to activate the pedestrian input. A warning light would typically be active during this delay. This delay can be set from zero seconds to four minutes in one second steps.

- **Pedestrian pre-close delay**

Sets the time delay between the pedestrian Autoclose timer expiring, and the shutter actually closing. A warning light would typically be active during this delay.



The warning light is any light wired to the courtesy (pillar) light contacts, as described in Menu 8, which follows.



## Menu 8 - Courtesy (pillar) light

This feature is associated with the LIGHT connections on the controller.

The pillar light circuit has multiple functions:

- It operates as a courtesy light and switches on for a timed period every time the shutter is activated.
- It can also be turned on for the same timed period by momentarily connecting the AUX input to COM.(eg activating a pushbutton connected to these terminals)
- Via the same pushbutton connected across AUX and COM, it can also be turned ON permanently by application of an impulse longer than 3 seconds. The fact that the pillar light is ON permanently is indicated by the STATUS LED flashing once every second. A short impulse thereafter will switch the lights off.



The roller-shutter will not open when using the **Aux** trigger input.

- When the PED input is triggered the courtesy light flashes for an adjustable (1 to 255 seconds) pre-flash time before opening to the pedestrian opening.

- **Courtesy light time**

The time that the courtesy light will remain activated can be set from 4 seconds to 10 minutes.

- **Light profile**

- The courtesy light can be selected to operate according to one of the following:

- **Courtesy light**

If pre-flashing Mode A, B or C is selected, the courtesy light circuit will activate for the selected pre-opening and pre-closing delay. The manner of activation is dependent on the pre-flashing mode selected.

- **Mode A** will turn on the courtesy light only while the motor is running
- **Mode B** will flash the courtesy light during the pre-opening delay, as well as while the shutter is running
- **Mode C** will turn on the courtesy light during the pre-opening delay, as well as while the shutter is running. In these pre-flashing modes, the timed courtesy light functionality is not available.



## Menu 9 - ChronoGuard (Time periods)

- **ChronoGuard** (a world first) is a powerful feature which has been added to the new generation CENTURION controllers. An integral Real Time Clock (RTC) is used to provide time-based functionality, including the automatic activation or time-barring of specific controller inputs, and the time-barring of specified remote control buttons used together with the onboard CENTURION code-hopping receiver.

- The RTC will keep time for a minimum of one hour without any power
- Time-periods

- **Time Periods**

A Time-period is defined by a start and end date and time. Up to 100 Time-periods can be defined. A Time-period can be a once off event, or can be set to repeat on a weekly or annual basis. The weekly repeat can be chosen to occur on every day of the week, weekdays only, weekends only, or any specific day. The minimum duration of a Time-period is one minute. **Once off** Time-periods have the highest precedence, followed by **annual** and then **weekly**. When appropriate, a "Tp" icon will appear on the display to indicate that a **Time-period** is active.

- **Auto-activations (Auto function)**

The following controller **inputs** can be set to activate automatically during a Time-period:

- Free-exit (FRX)
- Pedestrian opening (Ped)
- Holiday Lockout (Lck)
- Closing beam (IRBC)
- Courtesy light control (Aux)

During the relevant Time-period, the selected input will be activated. Where appropriate, the diagnostic LED of the relevant input will illuminate.

- **Time-barring**

Time-barring of **inputs** is divided into physical inputs and RF inputs (inputs mapped to a CENTURION code-hopping transmitter button)

The following **physical inputs** can be **Time-barred** (prevented from operating) during a Time-period:

- Trigger (Trg)
- Pedestrian opening (Ped)
- Free-exit (FRX)
- Holiday Lock (Lck)
- Courtesy light control (Aux)

The following physical **outputs** can be **Time-barred** (prevented from operating) during a Time-period:

- Courtesy (pillar) light relay (Light)

The following **RF inputs** can be **Time-barred** (prevented from operating) during a Time-period:

- Trigger (Trg)
- Pedestrian opening (Ped)
- Free-exit (FRX)
- Holiday Lock (Lck)
- Courtesy light control (Aux)



Time-barring of a CENTURION code-hopping transmitter is specified at the time of coding the transmitter into the system. Once an RF input is defined as time-barred, any **Time-barred** transmitter associated with that input will be time-barred during the relevant **Time-period**. If a physical or RF input is currently **Time-barred**, any attempt to activate it will be acknowledged by a short beep of the onboard buzzer. The input, however, will not activate.

- **Exclusions**

Exclusions are used to prevent scheduled **Time-periods** from occurring at specific times (eg: public holidays). While **Time-barring** can be used to achieve a similar end, exclusions can also be used to exclude **Time-barring** itself. Each exclusion consumes one **Time-period**. Exclusions have the highest precedence, followed by **Time-barring** and then **auto-activations** (auto function).



## Menu 10 - General features

- **Operating Standard**

Regional operating standards can be set. Applying this setting will automatically configure the controller settings to conform to the specific region's standard - e.g. UL325 or CE.

- **Reset options**

The controller settings can be reset through the **reset options** menu. Various reset options are available:

- **Factory Defaults** – Depending on the operating standard / profile chosen all these settings will be restored. No other settings such as remote controls, limit switch settings will be affected.
- **Delete All Remotes** - Delete all the remotes stored in the system, no settings affected.
- **Reset All** – Clears the system completely as per an off the production line unit.

- **Diagnostic screen**

Allow a diagnostic screen to be displayed. Can be useful when troubleshooting, but requires some technical knowledge.

- **Round test button**

Allows the round test button on the controller to be disabled, in cases where higher security is required.



## Menu 11 - Remote controls

The controller is capable of learning up to 500 CENTURION code-hopping remote controls / transmitters. Each transmitter can have up to four buttons. Each transmitter learned into the system is assigned a unique transmitter ID.

- It is possible to artificially increase the number of buttons of a multi-button transmitter by using a two button combination
- One of the buttons is used as a **shift button** to allow the other buttons to be used again in combination with this button. In other words the user will press and hold the shift button, before pressing one of the other buttons to create a **new** button
- The shift button cannot be used as a button on its own, it must always be used in combination with the other buttons



### Benefits of the shift button system:

- Use of the **shift button system** allows a three button transmitter to gain an extra button and operate four functions and likewise a four button transmitter gains two extra buttons and can operate six functions
- Another benefit of using the shift button system is that **it requires both hands to operate the two button combination**. This prevents the user from accidentally enabling sensitive functions such as Holiday Lockout on the controller



Each transmitter learned into the system is assigned a unique transmitter ID.

- **Press valid button**

If the **remote controls menu** has been locked as discussed later, only by pressing a button of a transmitter learned into the system, can the **remote controls menu** be accessed.

- **Add remote**

Any button can be set to control the trigger, pedestrian, free-exit, Holiday Lockout or courtesy light inputs. When adding transmitters it is recommended that a record be kept of the ID number allocated by the system to each respective transmitter and the person to whom the transmitter is given. This is necessary should selective deletion be required at a later stage.

- **Delete remote**

Transmitters can be edited at any stage according to one of the following:  
Delete Remote ID - Each transmitter can be deleted individually according to its unique ID. To facilitate this, a record of the ID and the person to whom the ID has been assigned must have been made at the time of learning the transmitter into the system.

- **Delete Remote Button -**

The operation of a button on a particular transmitter can be cleared i.e. it allows for instance Holiday Lockout set on one remote to be cleared without affecting the other operations that the transmitter performs.

- **Delete remote by button**  
Use this procedure to remove the transmitter from the system. All button functionality will be removed. The transmitter is required for this operation.
- **Delete-Not-Present**  
Allows for transmitters that have not been used within a selectable time period to be removed from the system. The Time-period can be set from one hour to seven days, in one hour increments.
- **Delete all remotes**  
Clears the entire memory. All transmitters will be removed.
- **Edit remote button**  
Change the function of one button to another.
- **Autolearn**  
Allows a Time-period to be set, during which any specific button will be learned to a specific function when it is pressed. The function will also be activated when the button is pressed. After the Time-period has expired Autolearn is disabled, and no further buttons will be learned.
- **Tx menu locked**  
Allows the "Remote Controls" menu to be locked, preventing the unauthorized addition of new transmitters to the system. Once enabled, the "Remote Controls" menu can only be accessed by pressing a valid transmitter button
- **Onboard receiver**  
The onboard CENTURION code-hopping receiver can be disabled in the unlikely event that it causes interference with an existing external receiver

### Fuse protection

Item	Type	Rating
<b>Main controller</b>		
Motor circuit	Automotive fuse ATO (25 x 7mm)	30A
Light circuit	5 x 20mm	3A fast blow
Auxiliary supply	Electronic limit	300mA
<b>Charger</b>		
Mains input	5 x 20mm	3A fast blow*

\* Not user serviceable

## RSO5DC Diagnostic LEDs

The **RSO5DC** controller has a series of diagnostic **LEDs** which indicate the state of the inputs. Normally-open inputs are indicated by a **RED LED**, and normally-closed inputs by a **GREEN LED**. An illuminated **RED LED** indicates that the signal is present (e.g.: intercom button pressed), while an illuminated **GREEN LED** indicates that the signal is absent (e.g.: IRB not broken).

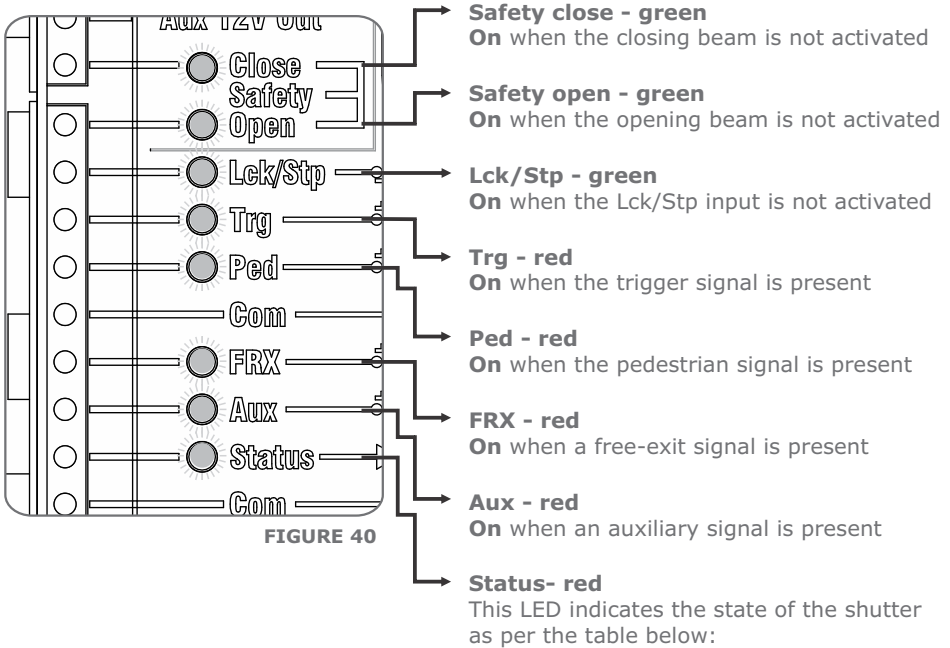

FIGURE 40

## RSO5DC Roller-shutter status LED

Off	Shutter is closed
On	Shutter is partially / fully open
Continuous slow flash	Shutter is opening
Continuous fast flash	Shutter is closing
1 flash every 2 seconds	Pillar light override is activated
2 flashes every 2 seconds	No mains is present
3 flashes every 3 seconds	Battery voltage is low
4 flashes every 2 seconds	Multiple collisions have occurred



# RS05DC LCD display

The LCD display shows useful information regarding the status of the system.

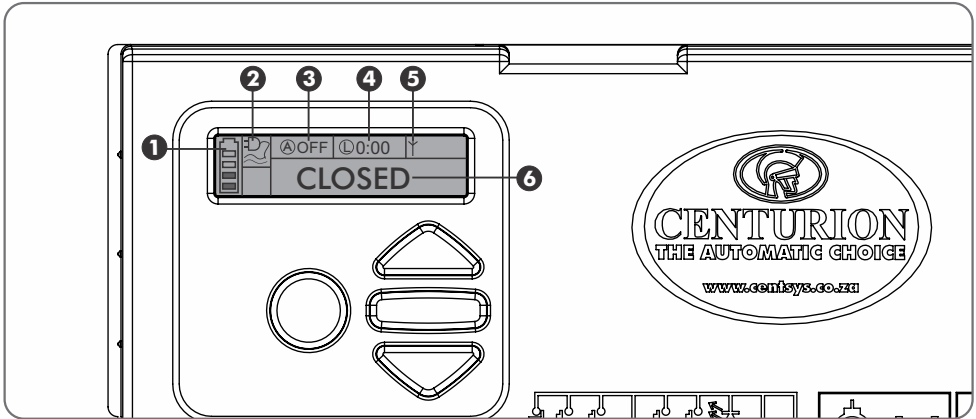

FIGURE 41

## 1. Battery icon

Indicates the state of charge of the battery.

- Four solid bars = full capacity
- Two solid bars = 50% capacity
- No solid bars, with the icon flashing = battery empty

## 2. Mains icon

Displays the presence/absence of mains voltage:

- Plug solid = mains present and battery charging
- Plug hollow and flashing = No mains present and battery not charging

## 3. Autoclose information

- Displays the state of the Autoclose function
- Displays off if Autoclose is not selected
- OVR if Autoclose is overridden, and the remaining Autoclose time if Autoclose is active
- POVR indicates that the PIRAC option is overridden

## 4. Pillar light information

- Displays the remaining light time if Courtesy Light Mode is selected
- Pre-flashing mode is displayed if pre-flash is selected
- LIT will be indicated if the pillar light has been turned on permanently

## 5. Onboard receiver information

Displays the current input being activated by the onboard receiver.

## 6. Status information

Displays useful information regarding the status of the shutter.

## RSO5DC Buzzer feedback

A warning buzzer will sound (where applicable) as per the table below:

Inhibitor name	Priority	Number of beeps	Fault type	Gate continues to operate	User can correct error
Break-in alarm	1	Continuous tone for 30 seconds	Alarm	N/A	N/A
Ambush alarm	2	Continuous tone until IRBs are cleared	Alarm	N/A	N/A
Battery low	4	3 beeps periodically for 30 seconds	Power system fault	Yes*	Yes
Multiple collision	3	Periodic until condition is cleared by user (500/500ms)	Collision	No	Yes
Auxiliary overload	5	5 beeps periodically for 30 seconds	Hardware	No	No
Holiday Lockout	6	1 beep periodically for 30 seconds	User	No	Yes
Emergency stop	7	1 beep periodically for 30 seconds	User	No	Yes
Time-barring	8	1 beep periodically for 5 seconds	User	No	Yes
No limits set	9	3 short beeps for 5 seconds	Lost	No	Yes
Mains failure	10	2 beeps periodically for 30 seconds	Power system fault	Yes	Yes
Beams broken (any)	11	1 beep periodically for 30 seconds	User	No	Yes
Beams failure	12	5 beeps periodically for 30 seconds	Hardware	No	No
Fuse blown	14	5 beeps periodically for 30 seconds	Hardware	No	Yes
Motor disconnected	15	5 beeps periodically for 30 seconds	Hardware	No	Yes
Bridge damaged	16	5 beeps periodically for 30 seconds	Hardware	No	No
Shutter stalled	17	4 beeps periodically for 10 seconds	Collision	No	Yes

\* Shutter will close fully and then shut down for two minutes

# RSO5DC factory defaults schedule

## South African standard profile - ZA

Parameter Description	Unit	Minimum	Default	Maximum
<b>Menu 1 - not applicable</b>				
<b>Menu 2</b>				
Opening collision force	Level	1	3	Max
Closing collision force	Level	1	3	Max
Collision count	Collisions	1	4	255
Alarm output	B, CL, SC, LED		B	
LCK as ESTOP	Yes or No		No	
<b>Menu 3</b>				
Autoclose status	On/Off		Off	
Autoclose timer	mm:ss	00m:00s	00m:15s	04m:00s
Autoclose override time	mm:ss	00m:00s	00m:03s	04m:00s
Autoclose from fully open	On/Off		On	
Autoclose from partly open	On/Off		On	
Autoclose from partly closed	On/Off		Off	
<b>Menu 4</b>				
Modes of Operation	S, C, R, P, D		S	
<b>Menu 5</b>				
PCM status*	On/Off		Off	
PCM force	%	10%	30%	100%
Pre-open delay time	mm:ss	00m:00s	00m:00s	01m:05s
Pre-close delay time	mm:ss	00m:00s	00m:00s	01m:05s
Opening speed	%	22%	Max	Max
Closing speed	%	100%	Max	Max
Ramp-up distance	% Travel	2%	5%	30%
Ramp-down distance	% Travel	2%	5%	11%
TRG stop distance	% Travel	1%	3%	10%
IRB stop distance	% Travel	1%	3%	10%
Crawl distance	% Travel	5%	10%	30%
Torque limit	A	4A	15A	15A
<b>Menu 6</b>				
PIRAC control	On/Off		Off	
Stop on open	On/Off		Off	
Stopping distance	%	0%	2%	5%
IR beam test	On/Off		Off	
Test beam	IRBC/IRBO/both		IRBC	
IRBO=IRBC	On/Off		Off	

\* Not advisable for roller-shutters

Parameter Description	Unit	Minimum	Default	Maximum
<b>Menu 6 (continued)</b>				
Ambush alarm	On/Off		Off	
Ambush time	hh:mm	00h:01m	00h:01m	04h:00m
Break-in alarm	On/Off		Off	
Alarm output	B, CL, SC, LED		B	
<b>Menu 7</b>				
PED opening	%	0.05m	1m	see note*
PED Autoclose	mm:ss	00m:00s	00m:05s	04m:25s
PED pre-open delay	mm:ss	00m:00s	00m:02s	04m:00s
PED pre-close delay	mm:ss	00m:00s	00m:00s	04m:00s
<b>Menu 8</b>				
Light timer	h:mm:ss	0h:00m:04s	0h:02m:00s	9h:59m:59
Light profile	CL, PFA, PFB, PFC		CL	S
<b>Menu 9 - not applicable</b>				
<b>Menu 10</b>				
Operating Standard	Z,C,U		ZA	
Factory defaults	Yes/No		No	
Delete all remotes	Yes/No		No	
Reset All	Yes/No		No	
<b>Menu 11</b>				
Delete-Not-Present	On/Off		Off	
Autolearn	On/Off		Off	
Tx Menu lock	On/Off		Off	
Onboard receiver	On/Off		On	
*Limited by gate length				

## Legend

B	Onboard buzzer	PFA	Pre-flashing mode A
C	Condominium mode	PFB	Pre-flashing mode B
CL	Courtesy light	PFC	Pre-flashing mode C
D	Deadman Control Mode	R	Reversing Mode
IRBC	Closing safety beams	S	Standard Mode
IRBO	Opening safety beams	SC	Safety common
LED	Status LED	Tx	Transmitter
P	PLC mode		

# Power connections

- **RS05, RS05R** and **RS05RE** variants must be connected to a 220V AC and **RS09** and **RS05R3P** to a 380V AC mains supply via the power supply cables provided with the kit. The cables are connected to the respective power supply units during the assembly process; however, should any of the connections come loose, the diagrams below illustrate the terminals to which they should be connected in each case



Ensure that all electrical power to the operator is disconnected before attempting to conduct any work on the power supply of the operator. All work should be carried out by a suitably qualified technician

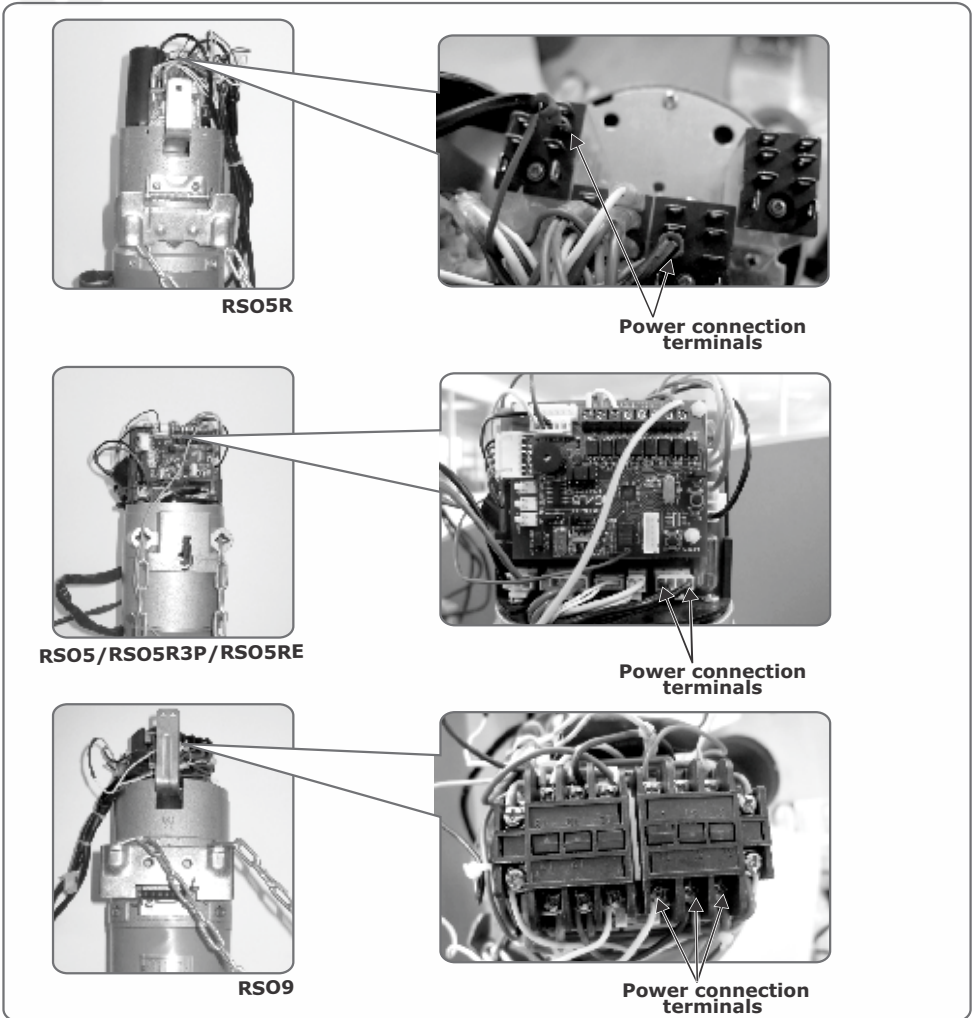

FIGURE 42. POWER CONNECTIONS

# 13. Setting the Travel Limits

## The limit switch assembly

- In order for the door to stop in the desired open and closed positions, the strikers must be adjusted to activate the corresponding limit switches for each position.

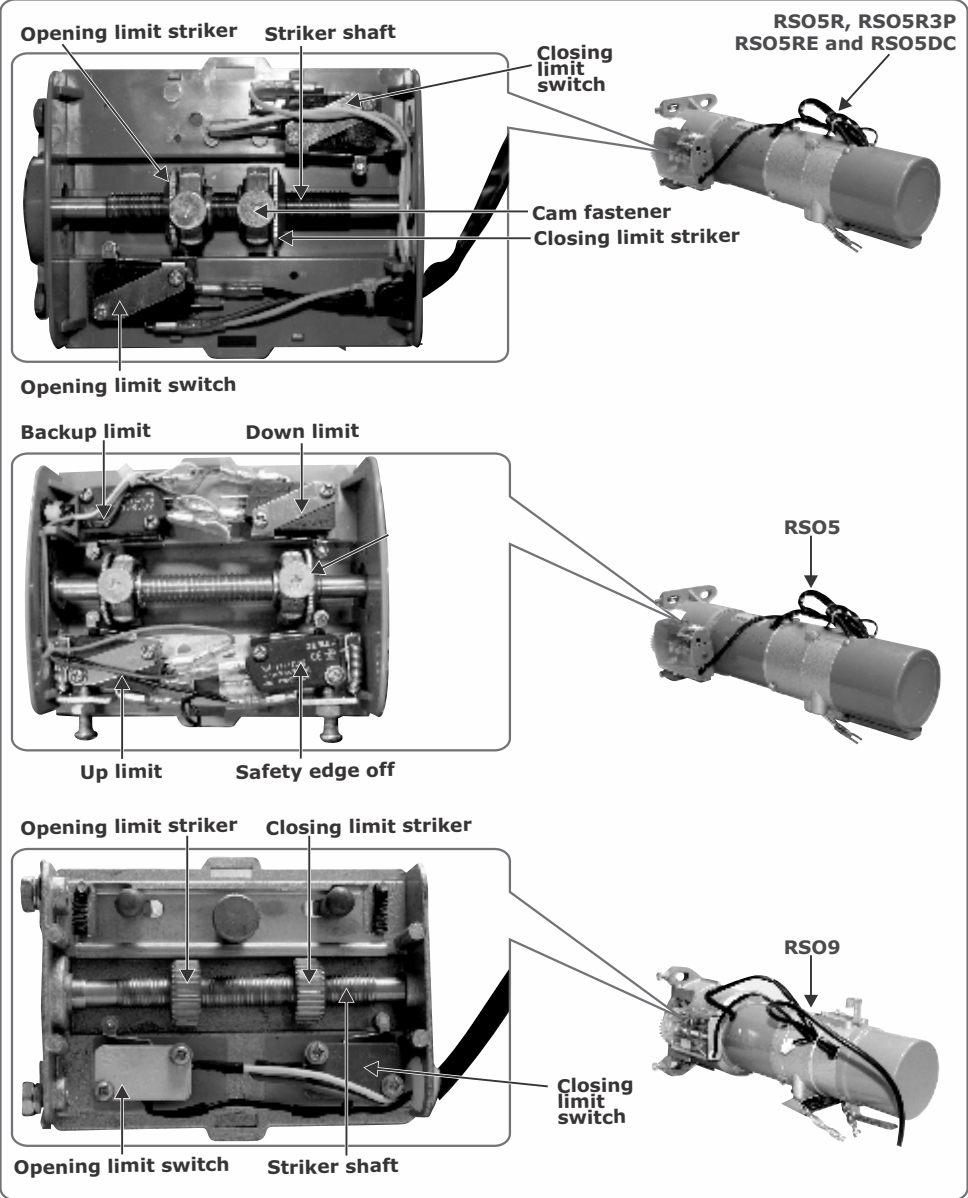

FIGURE 43

## RSO5, RSO5R, RSO5RE and RSO5R3P



The RSO5 provides a total of four limit micro-switches. In addition to the open and closed switches, provision has also been made for a Safety Edge Off switch as well as a Backup Limit (for the open position) switch. The Safety Edge Off switch will be triggered first when the shutter is travelling towards its closing limit, and serves to disable the sensitive edge fitted to the leading edge of the shutter (if installed). This is done to ensure that the collision circuitry does not activate and cause the shutter to re-open once it has reached the fully closed position.

The Backup Limit switch serves as a failsafe should the open limit switch malfunction, and will stop the shutter in the open position.

### To set the limits:

- Make use of a small flat screwdriver to open the limit switch housing
- Use a Phillips screwdriver to loosen the two cam fasteners.
- Using the hand chain, manually hoist the shutter until it is in the desired open position.
- Turn the opening striker by hand along the shaft until it is activating the corresponding micro-switch for the open position.
- Now use the hand chain to hoist the shutter until it is in the desired closed position.
- Turn the appropriate striker until it is activating the micro-switch for the closed position.
- Use the wall pendant to test the operation in both the opening and closing directions as well as to stop the motor. Ensure that the fasteners are tightened and that the strikers travel the desired distances for opening and closing before activating the limit switches. Upon triggering the motor, an audible beep will indicate that one of the limit switches is currently being activated.



It is advisable that the open limit is set slightly short from the fully open position to allow space for the safety limit to be activated.

## RSO5DC

Section 12 provides the full menu of features that can be set up on the system. An explanation of each feature is provided in Section 12, Controller features

When setting up the D10/D10 Turbo system via the LCD display, all the steps that have to be followed are clearly provided via the display. It is only necessary to note the following:

- To get into setup mode, press the enter (  ) button for two seconds and follow the instructions provided from there
- The buttons provided on the controller for navigating the system are not marked because at each step during the setup, the function given to each button is provided on the display

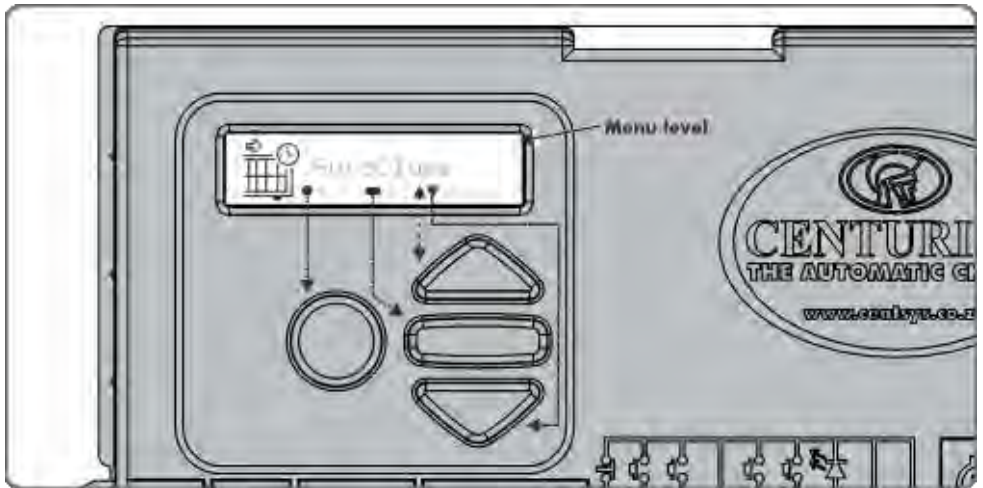

FIGURE 44

- When not in setup mode, i.e. normal mode, the ( ● ) button is used as a **test** button for operating the system
- The triangular up or down ( ◆ ) buttons are used to scroll through the diagnostic screens
  - For each feature a factory default setting has been programmed into the controller. Referred to as an operating standard or profile, these defaults have been determined to suit the requirements of the specific region where the installation is being carried out. It is only necessary to change a feature where the default does not suit the installation. When selecting any feature in the menu, details of the current setting stored in the controller are displayed
- Refer to Section 12 for the Schedule of factory defaults for each feature



If at any stage you wish to abort the limit setup procedure, simply disconnect one of the battery leads.

### To set the limits:

- Make use of a small flat screwdriver to open the limit switch housing
- Use a Phillips screwdriver to loosen the two cam fasteners.
- Turn both strikers by hand until they are more or less in the centre of the striker shaft.
- Using the hand chain, move the door to the desired open or closed position.
- Turning the corresponding striker by hand, move it until the micro-switch is activated. (click can be heard)
- Using the hand chain, move the door to the opposite position.
- Again using the hand chain move the door off the micro-switch so that neither of the micro-switches are being activated. Enter Setup Mode by pressing and holding the centre ellipse button for a period of two seconds.





Ensure that the cams are not activating either the open or the closed micro-switch before attempting to set the limits! If it is, first move the cams away from the switches by using the hand chain.

- Using the hand chain move the door off the micro-switch so that neither of the micro-switches are being activated. Enter Setup Mode by pressing and holding the centre ellipse button for a period of two seconds.
- Using the directional arrows, scroll to Menu 5: Run Profile and enter the menu by momentarily pressing the centre button.
- Now scroll to PWM Minimum and confirm the selection by momentarily pressing the centre button.
- Use the directional arrows to configure the PWM Minimum to a value of 90. Again, confirm the selection by pressing the centre button.
- Press the round button twice until it shows 'Run Profile' and scroll to Menu 1: Setting Limits. Enter the menu by pressing the centre button.
- You will now be guided through the limit setup procedure by an intuitive Setup Wizard. Carefully read each prompt on the display and confirm using the centre button.



Certain prompts are related to CENTURION sliding gate operators and might not be applicable

- The operator will complete four cycles in total; two to establish the position of the opening and closing limits, and two to confirm the positions.
- Once the procedure is complete, the Wizard will prompt you as to whether the shutter is open. If it is, simply confirm using the centre button. If, however, the shutter is in the closed position, toggle the display to NO and confirm with the centre button.
- The RSO5DC is now ready for use.
- Some fine adjustment of the strikers might be required. This can be done after completing the limit setup.

## RS09

While the procedure for setting the end-of-travel limits on the RS09 is more or less the same as with other RSO variants, there are subtle differences when it comes to securing the limit strikers.

### To set the limits:

- Make use of a flat screwdriver to open the limit switch housing.
- Ensure that the strikers can be rotated freely by hand; if they cannot, pull the securing studs towards you and away from the operator, and slide them to the opposite end of the vertical slot.
- Using the hand chain, manually hoist the shutter until it is in the desired open position.

- Turn the opening striker by hand along the shaft until it is activating the corresponding micro-switch for the open position.
- Now use the hand chain to hoist the shutter until it is in the desired closed position.
- Turn the appropriate striker until it is activating the micro-switch for the closed position.
- Once you are satisfied that the curtain travels the correct distance in both the opening and closing directions, secure the strikers again by pulling the securing studs towards you and then to the opposite end of the vertical slot, ensuring that the strikers cannot be moved by hand.
- Use the wall pendant to test the operation in both the opening and closing directions as well as to stop the motor. Ensure that the fasteners are tightened and that the strikers travel the desired distances for opening and closing before activating the respective limit switches.

## 14. Connecting an external radio receiver

### Connecting an external radio receiver\*

It is possible to connect an external receiver to the controller by making use of one of the four inputs provided. Incorporating a radio receiver will enable users to operate the door remotely.

Each input has the following operation associated with it:



For Standard Mode of Operation, connect the receiver's normally-open output to this terminal. Pressing the remote button once (from the fully closed position) will cause the door to start opening. Pressing the button a second time will cause the door to stop immediately, and a third button press will cause the door to move in the opposite direction, i.e. start closing



Connecting the receiver's normally-open output to this terminal will allow for a Close Only Mode of Operation. In other words, each button press will move the door in the closing direction only



Connecting the receiver's normally-open output to this input will cause the door to stop immediately



Connecting the receiver's normally-open output to this terminal will allow for an Open Only or Free-exit Mode of Operation. Pressing the remote button will only initiate an opening cycle

- In addition to these four inputs, +12V as well as ground are provided on the controller. Refer to Figure 40 for a visual representation of the connections
- Using a multi-channel receiver provides the user with the ability to activate the open, close and stop functions using three different buttons on the transmitter.

\* External receivers can only be connected to the **RS05 and RS05DC** models.

# 15. Connecting infrared beams

Infrared safety beams can be fitted and is recommended for enhanced safety. The **RSO5** controller\* offers a normally-open input which will, upon closing of the contact (i.e. the beams being broken), cause the door to stop immediately or to reverse direction, depending on whether the REV pins have been bridged on the controller. The installation of IR beams is considered critical as it helps prevent crushing

Infrared safety beams are connected to the controller as follows:

\*Infrared beams can only be connected to the **RSO5** and **RSO5DC** models

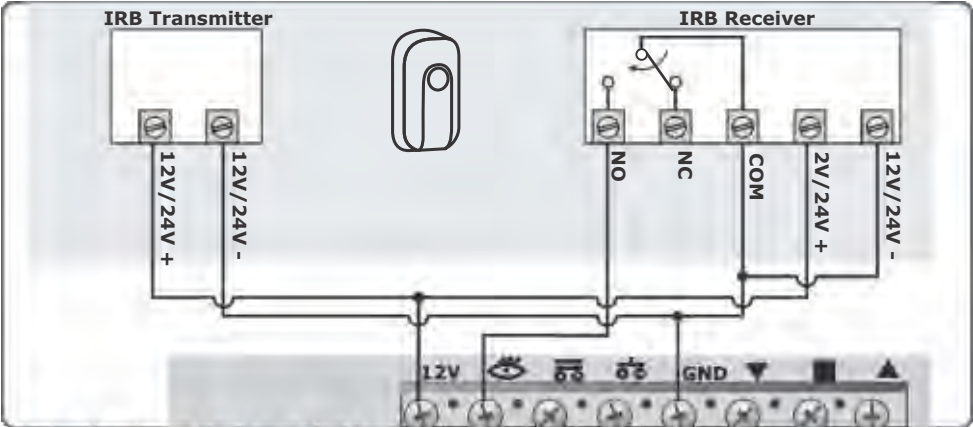

FIGURE 45. INFRARED BEAMS WIRING DIAGRAM FOR RSO5

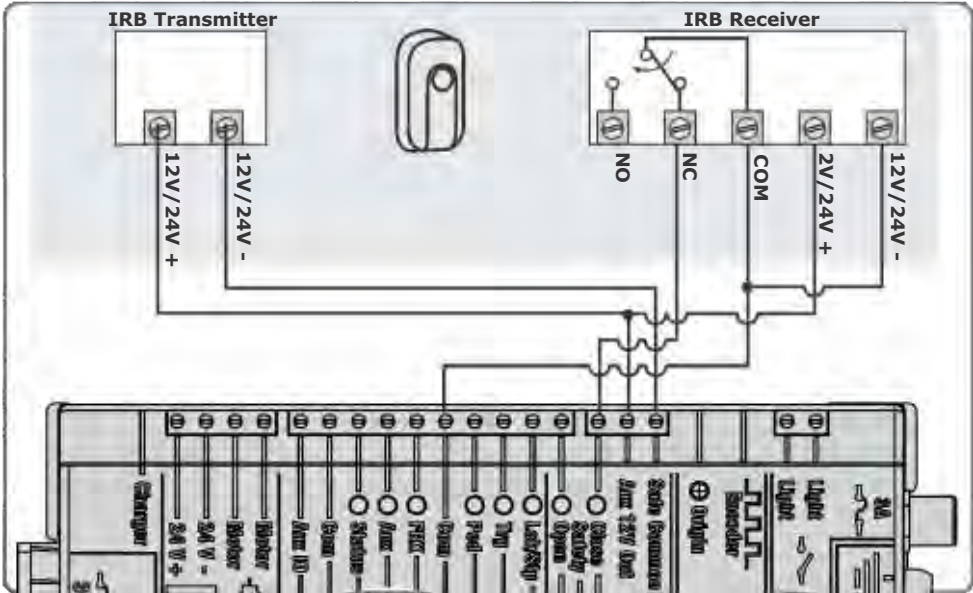

FIGURE 46. CLOSING INFRARED BEAMS WIRING DIAGRAM FOR RSO5DC

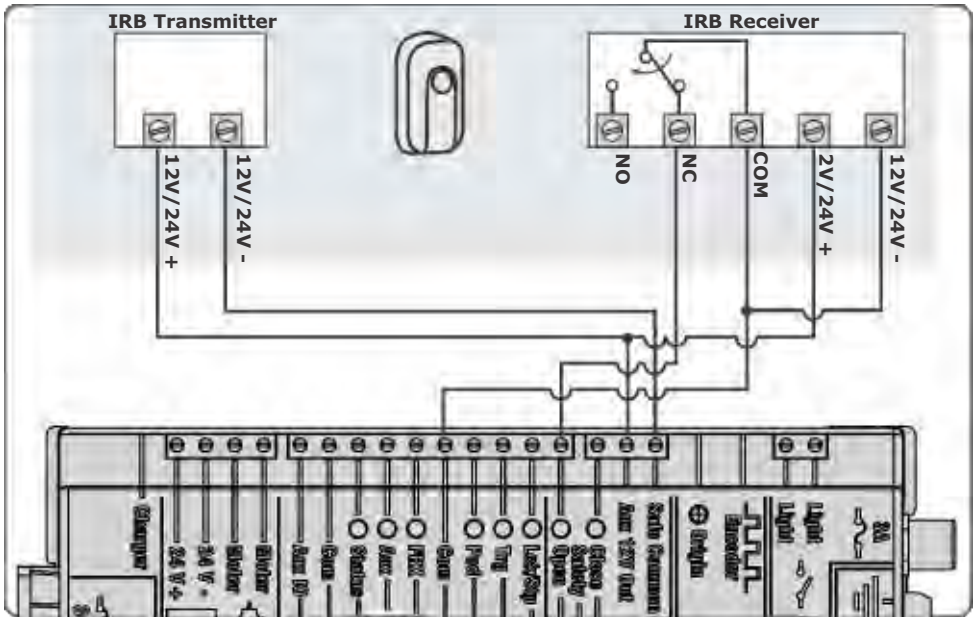

FIGURE 47. OPENING INFRARED BEAMS WIRING DIAGRAM FOR RSO5DC

# 16. RSO5DC Wiring diagram for other inputs

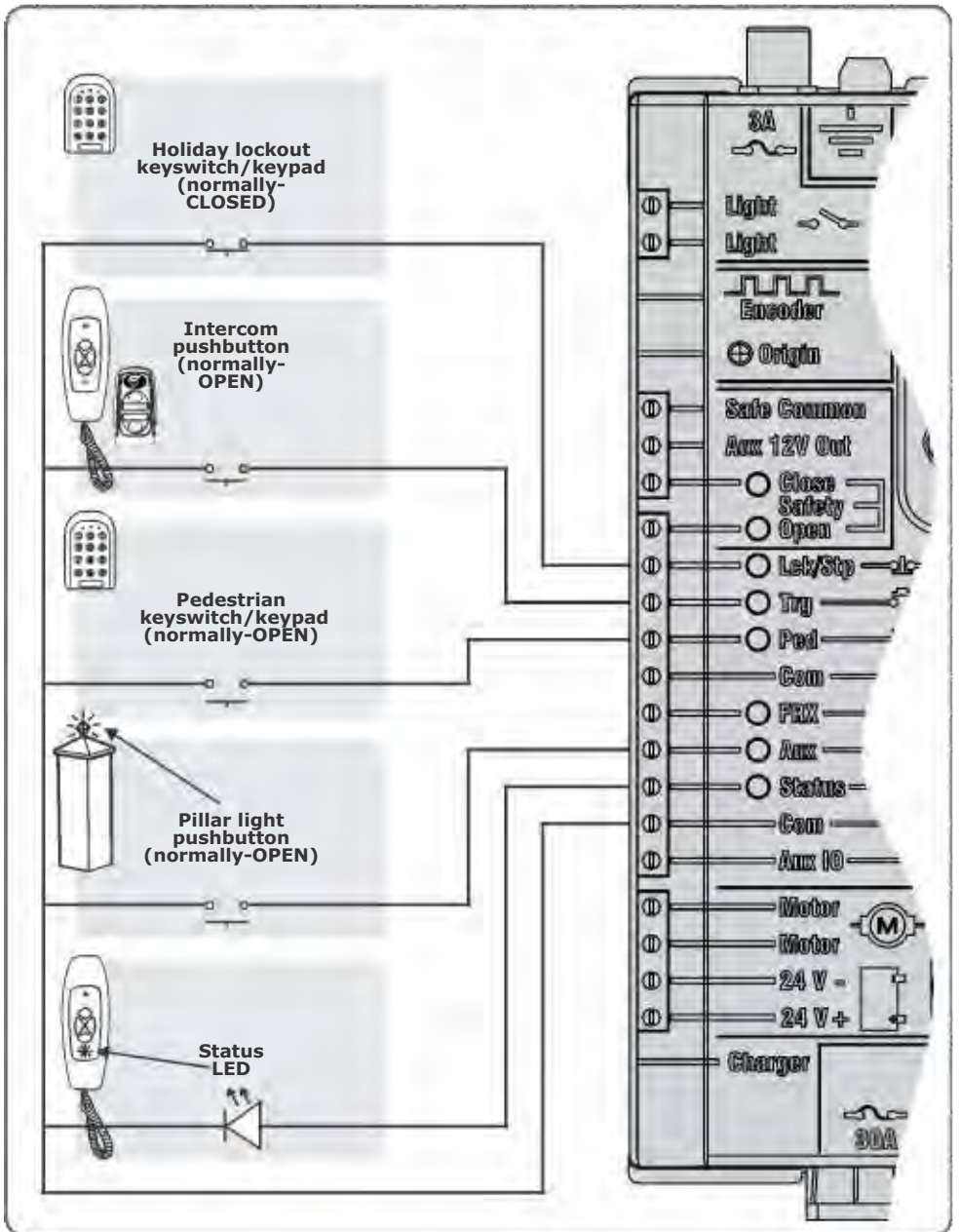

FIGURE 48

## 17. Manual operation

The CENTURION Industrial **RSO** offers two different modes of Manual Operation, namely complete disengagement of the gearbox – by overriding the mechanical braking mechanism - and chain-driven manual operation. A five metre chain has been provided with the system to allow for manual operation even from a floor-level.

- To completely disengage the gearbox, simply pull the manual override pin towards you, as indicated in Figures 44, 45 and 46. This will cause the operator's gearbox to be overridden and the door can then be operated by hand

If the door is completely or partially open, ensure that there are no people, pets or other obstructions directly underneath the door as disengaging the gearbox will release the door and possibly cause it to close at great speed, and could potentially cause serious injury or even death



For chain-driven manual operation, the gearbox must be engaged and the chain hoisted in the desired direction of travel

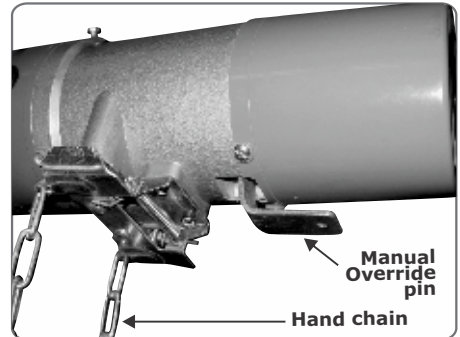

FIGURE 49. RSO5R, RSO5R3P AND RSO5RE MANUAL OVERRIDE

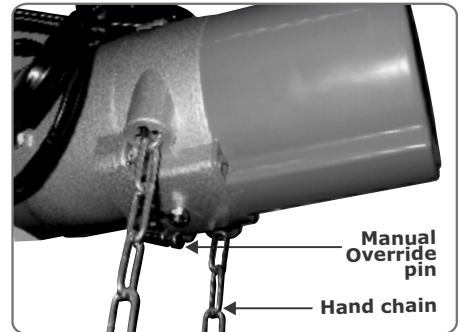

FIGURE 50. RSO5 and RSO5DC MANUAL OVERRIDE

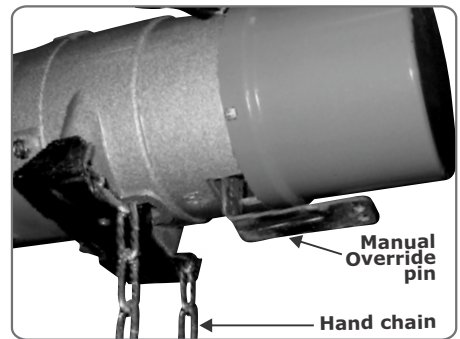

FIGURE 51. RSO9 MANUAL OVERRIDE

## 18. Installation handover

Once the installation has been successfully completed and tested, it is important for the installer to explain the operation and safety requirements of the system.

### **NEVER ASSUME THE USER KNOWS HOW TO SAFELY OPERATE THE RSO!**

Even if the user has used one before, it does not mean he knows how to SAFELY operate it. Make sure that the user fully understands the following safety requirements before finally handing over the site. Ensure that the end user has all the safety and user instructions included with the product

The following needs to be understood by the user:

- How to operate the manual release mechanism. **(Show them how by demonstration)**
- All the features and benefits of the operator, i.e. safety beams, etc.
- **All the safety considerations associated with operating an RSO. The user should be able to pass this knowledge on to all other users of the automated system and must be made aware of this responsibility**



- **Do not activate the RSO operator unless you can see it and can determine that its area of travel is clear of people, pets, or other obstructions**
- **NO ONE MAY CROSS THE PATH OF A MOVING ROLLER-SHUTTER. Always keep people and objects away from the entrance**
- **NEVER LET CHILDREN OPERATE OR PLAY WITH THE RSO operator CONTROLS, and do not allow children or pets near the entrance**
- **Be careful with moving parts and avoid close proximity to areas where fingers or hands could be pinched**
- **Secure all easily accessed RSO operator controls in order to prevent unauthorized use of the roller-shutter**
- **Keep the automated RSO system properly maintained, and ensure that all working areas are free of debris and other objects that could affect the RSO operation and safety**
- **On a monthly basis, check the safety devices for correct operation**
- **All repair and service work to this product must be done by a suitably qualified person**

**This product was designed and built strictly for the use indicated in this documentation. Any other use, not expressly indicated here, could compromise the good condition/operation of the product and/or be a source of danger!**



CENTURION SYSTEMS (Pty) Ltd does not accept any liability caused by improper use, of the product, or for use other than that for which the automated system was designed.



**Sharecall 0860-CENTURION (0860 236 887)**  
**Head Office: +27 11 699 2400**

**Sharecall Technical Support 0861 003 123 or**  
**+27 11 699 2481**  
from 07h00 to 18h00 (GMT+2)

**(Sharecall numbers applicable when dialed from within South Africa only)**



0.07.A.0005\_20032014

**[www.centsys.com](http://www.centsys.com)**